

540B

Thermal Transfer Standard

Instruction Manual

P/N 294033
March 1968



WARRANTY

Notwithstanding any provision of any agreement the following warranty is exclusive:

The JOHN FLUKE MFG. CO., INC., warrants each instrument it manufactures to be free from defects in material and workmanship under normal use and service for the period of 1 year from date of purchase. This warranty extends only to the original purchaser. This warranty shall not apply to fuses, disposable batteries (rechargeable type batteries are warranted for 90 days), or any product or parts which have been subject to misuse, neglect, accident, or abnormal conditions of operations.

In the event of failure of a product covered by this warranty, John Fluke Mfg. Co., Inc., will repair and calibrate an instrument returned to an authorized Service Facility within 1 year of the original purchase; provided the warrantor's examination discloses to its satisfaction that the product was defective. The warrantor may, at its option, replace the product in lieu of repair. With regard to any instrument returned within 1 year of the original purchase, said repairs or replacement will be made without charge. If the failure has been caused by misuse, neglect, accident, or abnormal conditions of operations, repairs will be billed at a nominal cost. In such case, an estimate will be submitted before work is started, if requested.

THE FOREGOING WARRANTY IS IN LIEU OF ALL OTHER WARRANTIES, EXPRESS OR IMPLIED, INCLUDING BUT NOT LIMITED TO ANY IMPLIED WARRANTY OF MERCHANTABILITY, FITNESS, OR ADEQUACY FOR ANY PARTICULAR PURPOSE OR USE. JOHN FLUKE MFG. CO., INC., SHALL NOT BE LIABLE FOR ANY SPECIAL, INCIDENTAL, OR CONSEQUENTIAL DAMAGES, WHETHER IN CONTRACT, TORT, OR OTHERWISE.

If any failure occurs, the following steps should be taken:

1. Notify the JOHN FLUKE MFG. CO., INC., or nearest Service facility, giving full details of the difficulty, and include the model number, type number, and serial number. On receipt of this information, service data, or shipping instructions will be forwarded to you.
2. On receipt of the shipping instructions, forward the instrument, transportation prepaid. Repairs will be made at the Service Facility and the instrument returned, transportation prepaid.

SHIPPING TO MANUFACTURER FOR REPAIR OR ADJUSTMENT

All shipments of JOHN FLUKE MFG. CO., INC., instruments should be made via United Parcel Service or "Best Way"* prepaid. The instrument should be shipped in the original packing carton; or if it is not available, use any suitable container that is rigid and of adequate size. If a substitute container is used, the instrument should be wrapped in paper and surrounded with at least four inches of excelsior or similar shock-absorbing material.

CLAIM FOR DAMAGE IN SHIPMENT TO ORIGINAL PURCHASER

The instrument should be thoroughly inspected immediately upon original delivery to purchaser. All material in the container should be checked against the enclosed packing list. The manufacturer will not be responsible for shortages against the packing sheet unless notified immediately. If the instrument is damaged in any way, a claim should be filed with the carrier immediately. (To obtain a quotation to repair shipment damage, contact the nearest Fluke Technical Center.) Final claim and negotiations with the carrier must be completed by the customer.

The JOHN FLUKE MFG. CO., INC., will be happy to answer all applications or use questions, which will enhance your use of this instrument. Please address your requests or correspondence to: JOHN FLUKE MFG. CO., INC., P.O. BOX C9090, EVERETT, WASHINGTON 98206, ATTN: Sales Dept. For European Customers: Fluke (Holland) B.V., P.O. Box 5053, 5004 EB, Tilburg, The Netherlands.

*For European customers, Air Freight prepaid.

John Fluke Mfg. Co., Inc., P.O. Box C9090, Everett, Washington 98206

Rev. 6/81

TABLE OF CONTENTS

Section	Title	Page
I	INTRODUCTION AND SPECIFICATIONS	1-1
	1-1. Introduction	1-1
	1-7. Specifications	1-1
	1-8. Electrical	1-1
	1-9. Mechanical	1-2
	1-10. Accessories	1-2
	1-11. High Frequency Thermal Converters.	1-2
	1-13. Current Shunts	1-2
II	OPERATING INSTRUCTIONS	2-1
	2-1. Controls, Terminals, and Indicators	2-1
	2-3. Auxilliary Equipment Needed	2-1
	2-6. Methods of Operation	2-3
	2-8. Preliminary Operation	2-3
	2-9. Precautions	2-3
	2-11. Battery Check	2-5
	2-13. Deflection Sensitivity.	2-5
	2-15. DC Reversal Error	2-5
	2-17. Voltage Measurement and Calibration	2-8
	2-18. Measuring an Unknown AC Voltage	2-8
	2-20. Calibrating an AC Voltage Source	2-8
	2-22. Current Measurement and Calibration	2-8
	2-23. General.	2-8
	2-28. Measuring an Unknown AC Current	2-8
	2-30. Calibrating an AC Current Source	2-8
	2-32. High Frequency Voltage Measurement and Calibration	2-10
	2-33. General.	2-10
	2-35. Measuring an Unknown High Frequency Voltage	2-10
	2-37. Calibrating a High Frequency Voltage Source	2-10
III	THEORY OF OPERATION	3-1
	3-1. Introduction	3-1
	3-3. General	3-1
	3-9. Circuit Descriptions	3-2
	3-10. Search Circuit.	3-2
	3-13. Protection Circuit	3-2
	3-19. Thermocouple	3-3
	3-21. Reference.	3-3
	3-23. Galvanometer	3-3
	3-29. Battery Check Circuits	3-4
	3-33. Rechargeable Battery Pack	3-5

(continued ii)

Table of Contents (continued)

Section	Title	Page
IV	MAINTENANCE	4-1
	4-1. General	4-2
	4-4. Battery Installation and Removal	4-2
	4-6. Battery Check Calibration	4-2
	4-9. Periodic Maintenance	4-3
	4-10. Search Meter Calibration	4-3
	4-12. Protection Amplifier Calibration	4-3
	4-14. Galvanometer Calibration	4-3
	4-18. Sensitivity Test Calibration	4-5
	4-19. Preliminary Transfer Calibration Check	4-5
	4-20. General	4-5
	4-24. Reversal Error	4-5
	4-28. Galvanometer Ground Isolation	4-5
	4-30. Galvanometer Input Isolation	4-6
	4-32. Protection Disable Check (Model A54-2)	4-6
	4-34. Transfer Calibration Check	4-6
	4-36. Troubleshooting	4-7
	4-37. General	4-7
	4-39. Thermocouple Replacement	4-7
V	LIST OF REPLACEABLE PARTS	5-1
	5-1. Introduction	5-1
	5-4. How to Obtain Parts	5-2
	5-7. List of Abbreviations	5-2
	5-8. Serial Number Use Codes	5-24
VI	ACCESSORIES	6-1
	6-1. Model A55 Thermal Converters	6-1
	6-2. Introduction	6-1
	6-4. Construction	6-1
	6-6. Specifications	6-2
	6-7. Accessories	6-2
	6-9. Model A40 and A40A Current Shunts	6-2
	6-10. Introduction	6-2
	6-12. Construction	6-2
	6-14. Specifications	6-3
	6-15. Accessories	6-3
VII	GENERAL INFORMATION	7-1
	7-1. List of Abbreviations	7-1
	7-2. Federal Supply Codes for Manufacturers	7-3
	7-3. Fluke Technical Service Centers	7-10
	7-4. Sales Representatives - Domestic	7-11
	7-5. Sales Representatives - International	7-13
VIII	SCHEMATIC DIAGRAMS	8-1
	Model 540B Transfer Standard	8-1
	Model A54-2 Voltage Plug-In Unit	8-2

LIST OF ILLUSTRATIONS

Figure	Title	Page
Frontispiece	540B Thermal Transfer Standard	v
2-1.	Location of Controls, Terminals, and Indicators	2-1
2-2.	Front-Panel Controls, Terminals, and Indicators (Sheet 1 of 2)	2-2
2-2.	Front-Panel Controls, Terminals, and Indicators (Sheet 2 of 2)	2-3
2-3.	Recommended Auxiliary Equipment	2-4
2-4.	Battery Check	2-5
2-5.	Deflection Sensitivity	2-6
2-6.	Measuring an Unknown AC Voltage	2-7
2-7.	Calibrating an AC Voltage Source	2-9
2-8.	Cables and Connections for Current Shunts	2-10
2-9.	Measuring an Unknown AC Current	2-11
2-10.	Calibrating an AC Current Source	2-12
2-11.	Measuring an Unknown HF Voltage	2-13
2-12.	Calibrating a HF Voltage Source	2-14
3-1	540B Block Diagram	3-1
3-2.	Simplified Balance Network	3-3
3-3.	Galvanometer Block Diagram	3-4
3-4.	540B Rechargeable Battery Pack	3-5

(continued iv)

List of Illustrations (continued)

Figure	Title	Page
4-1.	Calibration and Test Equipment	4-1
4-2.	Battery Check Calibration Adjustments	4-2
4-3.	Electronic Galvanometer Calibration	4-4
4-4.	Tuned Carrier Amplifier Adjustments	4-4
4-5.	Transfer Calibration Check	4-6
4-6.	Troubleshooting	4-7
5-1.	Final Assembly (Sheet 1 of 2)	5-3
5-1.	Final Assembly (Sheet 2 of 2)	5-4
5-2.	Front Panel Assembly	5-5
5-3.	Oscillator/Synchronous Demodulator	5-8
5-4.	Magnetic Modulator/Carrier Amplifier	5-11
5-5.	Search and Protection Amplifier Assembly	5-13
5-6.	A54-1 and A54-2 Final Assembly	5-15
5-7.	Panel Assembly	5-16
5-8.	Range Switch Assembly	5-19
5-9.	Range Board Assembly	5-20
5-10.	Compensation Board Assembly	5-21
5-11.	540B-110 Rechargeable Battery Kit	5-22
6-1.	Model A55 Thermal Converters and Accessories.	6-1
6-2.	Current Shunts	6-2
6-3.	Current Shunt Accessories	6-3

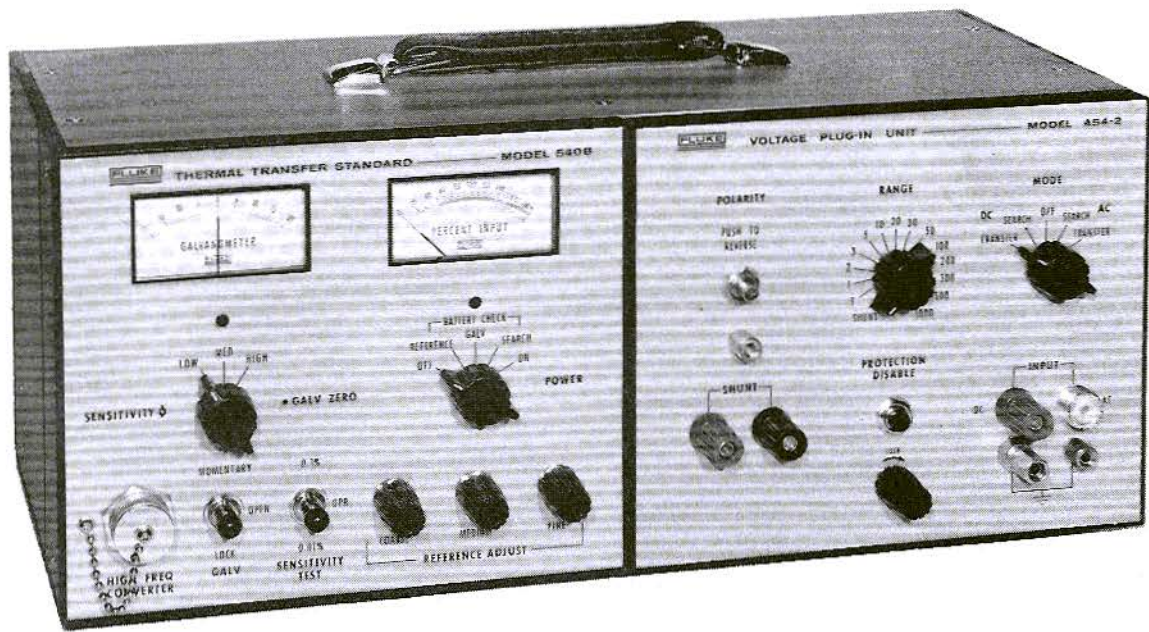

MODEL 540B THERMAL TRANSFER STANDARD



SECTION I

INTRODUCTION AND SPECIFICATIONS

1-1. INTRODUCTION

1-2. The Model 540B, together with the Model A54-1 or Model A54-2 Voltage Plug-In Units, constitutes an AC-DC Thermal Transfer Standard. The unit has 14 ranges of input from 0.5 volts to 1,000 volts. It is furnished complete with a solid-state galvanometer, internal reference, search meter and battery power supply. A voltage protection circuit protects all internal circuits from damage as a result of over-voltages of up to 1,500 volts on any range. Since the instrument does not require critical positioning or environment, it is suitable for application as a Laboratory Standard, yet hardy enough for use as a production line or field instrument.

1-3. The solid-state galvanometer does not require special mechanical orientation for proper operation and is no more fragile than any normal meter movement. The circuit is equipped with an internal calibration circuit that provides easy and rapid calibration of meter deflection sensitivity representing 0.1% and .01% at any input.

1-4. The internal reference is adjusted by Coarse, Medium and Fine controls that provide continuous adjustment over the entire range of input levels. Good resolution is possible at levels below 50% of rated input, but sensitivity is sacrificed with the lower levels of input.

1-5. A search meter function has been included which makes the selection of the operating range certain and rapid.

1-6. The self-contained battery pack will operate the instrument independent of power sources.

1-7. SPECIFICATIONS

1-8. ELECTRICAL

VOLTAGE RANGES

0.5, 1, 2, 3, 5, 10, 20, 30, 50, 100, 200, 300, 500 and 1000 volts. Transfers may be made on each range from 1/2 to 1 times range voltage. Transfers may be made at levels considerably below the 1/2 of range level, but at the sacrifice of sensitivity.

ACCURACY

Range	Frequency	AC/DC Difference
All except 1000v	5 Hz to 50kHz	±.01%
1000v	5 Hz to 20kHz	±.02%
1000v	20kHz to 50kHz	±.04%
0.5 thru 50v	50kHz to 100kHz	±.05%
20 thru 50v	100kHz to 500kHz	±0.1%
0.5 thru 10v	100kHz to 1MHz	±0.1%
100 thru 500v	50kHz to 100kHz	±0.2%

CALIBRATION

Each range is adjusted to be within the above deviations from zero as defined by reference standards maintained by the John Fluke Standards Laboratory, which are periodically calibrated by the National Bureau of Standards. These AC/DC difference specifications do not include the National Bureau of Standards random and systematic error uncertainties. John Fluke Standards Laboratory or National Bureau of Standards calibration reports are available at extra cost.

INPUT IMPEDANCE

182 ohms/volt in all voltage modes.

THERMOCOUPLE REVERSAL ERROR

Less than 0.01% of input at 100% of rated current or voltage. Less than 0.03% at 50% of rated current or voltage.

GALVANOMETER

Solid-state electronic type with a resolution of 0.0012% of input/scale division at rated input. 0.006% of input/scale division at 1/2 of rated input.

SEARCH CIRCUIT

Solid-state circuit provides visual indication of input voltage as a percentage of the voltage range selected.

OVERLOAD PROTECTION

The entire instrument is protected from accidental overloads of up to 1,500 vdc or rms ac in any range.

PROTECTION DISABLE

A push button switch that removes the diode circuit from the input to the thermocouple. Incorporated only in the A54-2 plug-in unit.

1-9. MECHANICAL

SIZE

7" high x 17" wide x 7-3/4" deep (19" wide with 881A-103 rack mounting kit installed).

WEIGHT

18 pounds, 9 ounces with batteries.

1-10. ACCESSORIES

1-11. HIGH FREQUENCY THERMAL CONVERTERS

1-12. Nine Fluke Model A55 High Frequency Thermal Converters are available for use with the Model 540B extending the frequency response to 50 MHz. One is provided for each voltage range of the 540B from 0.5 volts to 50 volts, and may be used from 1/2 to 1 times their rated voltage. It is possible to use the Thermal Converters at levels below 1/2 their rated input by sacrificing sensitivity.

1-13. CURRENT SHUNTS

1-14. Fourteen Fluke Model A40 Current Shunts are available for use with the Model 540B, for current transfer measurements of 2.5 ma to 20 amps, over a frequency range of 5 Hz to 100 kHz with a basic transfer accuracy of $\pm 0.02\%$. Current transfer measurements may be made well below 2.5 ma, but sensitivity will be reduced.



static awareness



A Message From
John Fluke Mfg. Co., Inc.

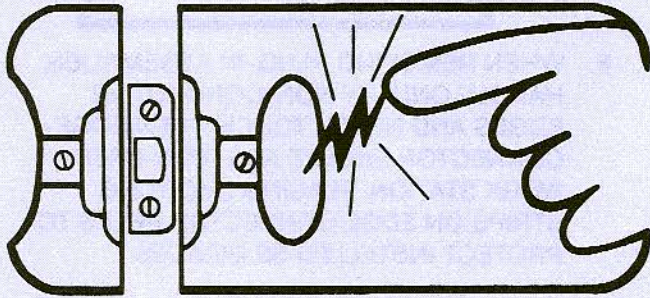

Some semiconductors and custom IC's can be damaged by electrostatic discharge during handling. This notice explains how you can minimize the chances of destroying such devices by:

1. Knowing that there is a problem.
2. Learning the guidelines for handling them.
3. Using the procedures, and packaging and bench techniques that are recommended.

The Static Sensitive (S.S.) devices are identified in the Fluke technical manual parts list with the symbol



The following practices should be followed to minimize damage to S.S. devices.

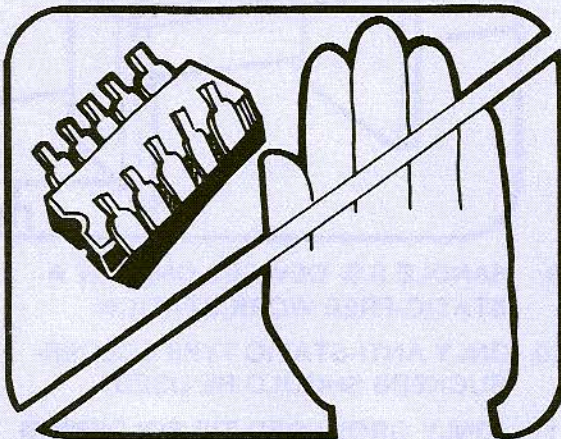

1. MINIMIZE HANDLING

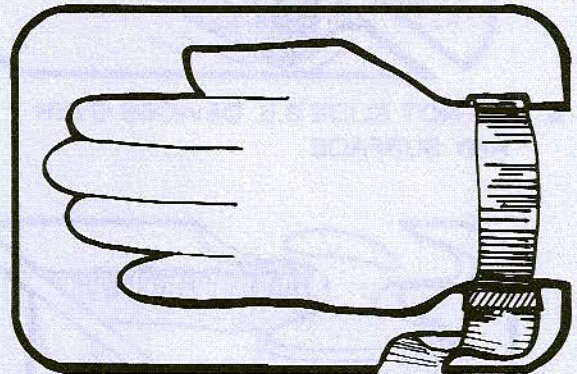

3. DISCHARGE PERSONAL STATIC BEFORE HANDLING DEVICES. USE A HIGH RESISTANCE GROUNDING WRIST STRAP.

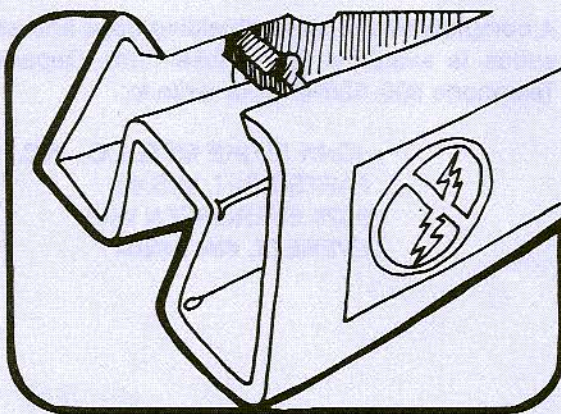

2. KEEP PARTS IN ORIGINAL CONTAINERS UNTIL READY FOR USE.

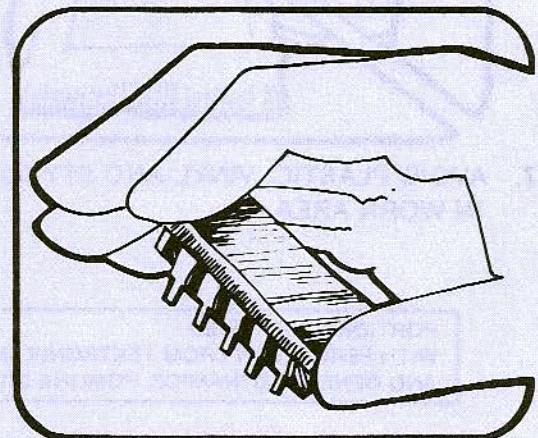

4. HANDLE S.S. DEVICES BY THE BODY

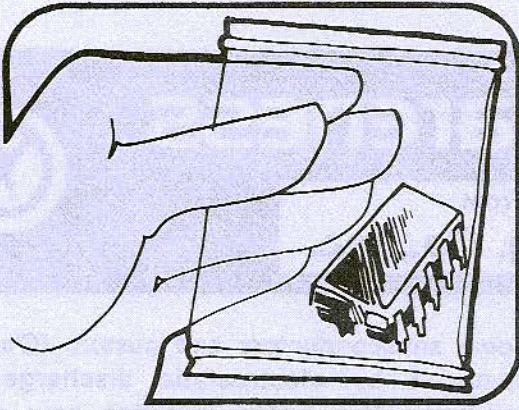

5. USE STATIC SHIELDING CONTAINERS FOR HANDLING AND TRANSPORT

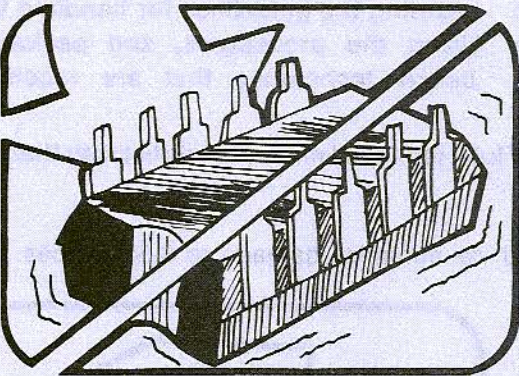

6. DO NOT SLIDE S.S. DEVICES OVER ANY SURFACE

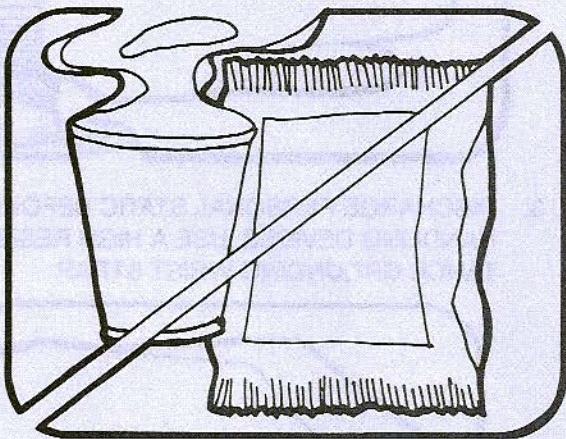

7. AVOID PLASTIC, VINYL AND STYROFOAM® IN WORK AREA

PORTIONS REPRINTED
WITH PERMISSION FROM TEKTRONIX, INC.
AND GENERAL DYNAMICS, POMONA DIV.

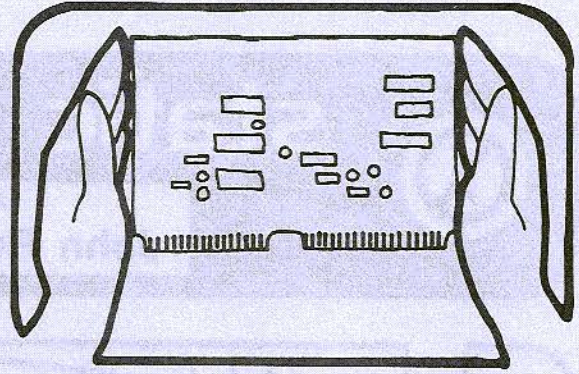

8. WHEN REMOVING PLUG-IN ASSEMBLIES, HANDLE ONLY BY NON-CONDUCTIVE EDGES AND NEVER TOUCH OPEN EDGE CONNECTOR EXCEPT AT STATIC-FREE WORK STATION. PLACING SHORTING STRIPS ON EDGE CONNECTOR HELPS TO PROTECT INSTALLED SS DEVICES.

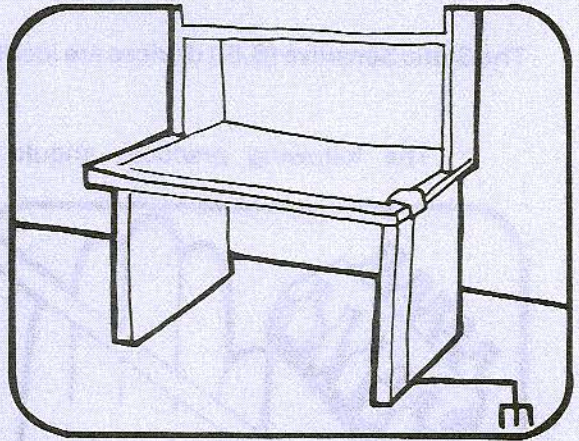

9. HANDLE S.S. DEVICES ONLY AT A STATIC-FREE WORK STATION
10. ONLY ANTI-STATIC TYPE SOLDER-SUCKERS SHOULD BE USED.
11. ONLY GROUNDED TIP SOLDERING IRONS SHOULD BE USED.

A complete line of static shielding bags and accessories is available from Fluke Parts Department, Telephone 800-526-4731 or write to:

JOHN FLUKE MFG. CO., INC.
PARTS DEPT. M/S 86
9028 EVERGREEN WAY
EVERETT, WA 98204

SECTION II

OPERATING INSTRUCTIONS

2-1. CONTROLS, TERMINALS AND INDICATORS

2-2. The location, circuit symbol, and a functional description of the external controls, terminals and indicators on the Model 540B may be found in Figures 2-1 and 2-2.

Note!

Warranty and shipping information found on Warranty page at rear of manual.

2-3. AUXILIARY EQUIPMENT NEEDED

2-4. The Model 540B Thermal Transfer Standard with the equipment listed in Figure 2-3 will form a complete

system capable of measuring an ac voltage or current, calibrating ac voltage or current measuring devices and measuring frequency response. Since all transfer measurements are made by comparison, accuracy is dependent upon the accuracy of the transfer standard and the accuracy of the dc measuring equipment. It is also necessary that the ac being measured must be at least as stable as the degree of accuracy desired. The National Bureau of Standards will check a Model 540B and issue a test report at specified frequencies and voltages upon request. However, as requested by the National Bureau of Standards, we suggest that these tests can be done in the Fluke traceable standards laboratory. This helps reduce the National Bureau of Standards work load and also reduces customer waiting time.

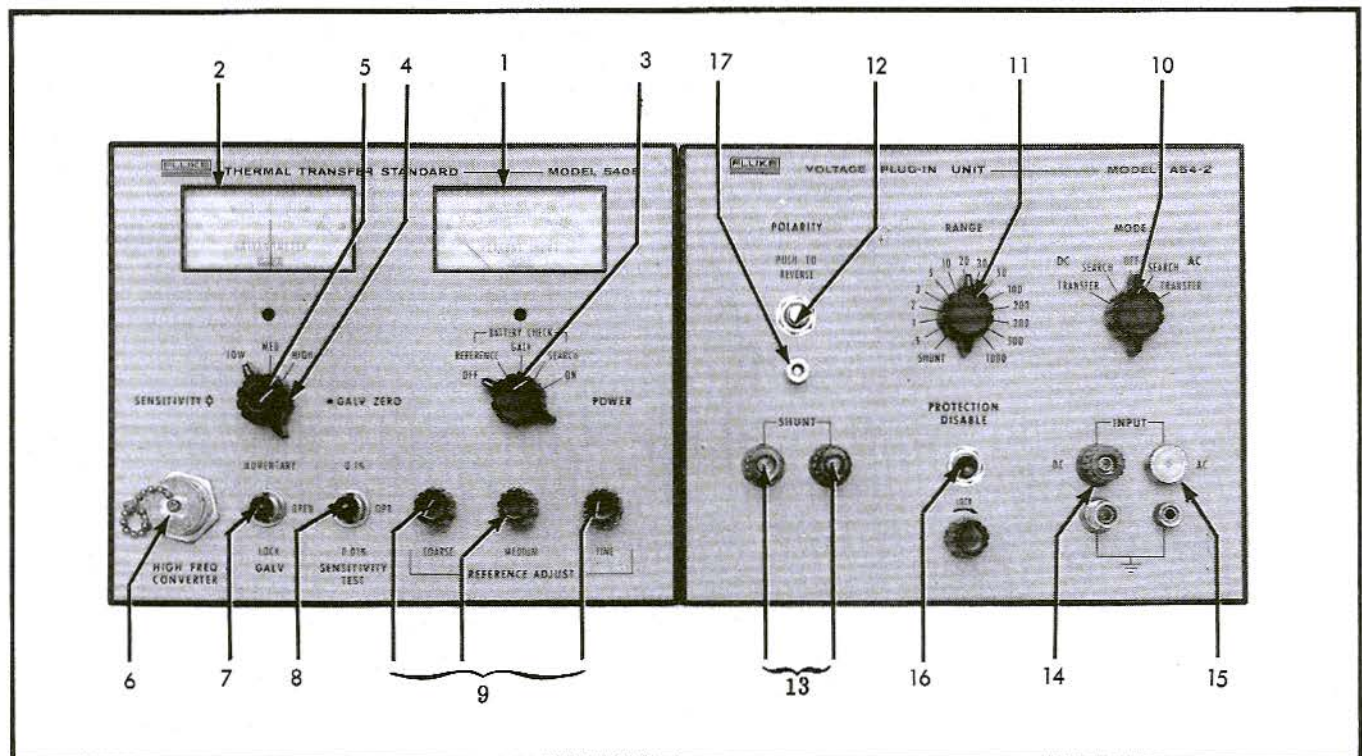

Figure 2-1. LOCATION OF CONTROLS, TERMINALS AND INDICATORS

REF NR.	NAME	REF DESIG	FUNCTION
1	PERCENT INPUT	M 101	Search circuit indicator which reads % of input/range selected. Indicates battery condition, which is adequate when the meter reads above the lower limit of the BAT band on the meter scale. Indicates that the protection circuit has operated and needs resetting, when the needle is in the OVER LOAD area. Does not function in current shunt operation.
2	GALVANOMETER	M 102	The null indicating device used to determine the balance between the variable reference voltage and the thermocouple output.
3	POWER	S 101	Applies battery power to the instrument in the ON position. When in the BATTERY CHECK; REFERENCE, GALV or SEARCH positions the PERCENT INPUT meter will indicate the condition of each set of batteries.
4	SENSITIVITY	S 105	Used to select the range of galvanometer sensitivity; LOW, MED and HIGH.
5	GALV ZERO	R 4	The electrical zero adjustment for the galvanometer.
6	HIGH FREQ CONVERTER	J 102	Used to attach an external high frequency converter, such as the Fluke Model A55 Thermal Converters, to the instrument. May also be used to connect an external galvanometer. When not in use the three-prong captive plug P 101, must be plugged in.
7	GALV	S 104	Electrically connects the galvanometer circuit between the thermocouple output and the variable internal reference when in the LOCK or MOMENTARY positions. The GALV switch is briefly pushed from OPEN to MOMENTARY to determine if the galvanometer will indicate on scale without further adjustment. After an on scale indication is obtained, the GALV switch may be set to LOCK.
8	SENSITIVITY TEST	S 102	Used to determine the amount of deflection of the galvanometer for 0.1% and 0.01% changes in input.
9	REFERENCE ADJUST	S 103 R 405 R 408	The COARSE, MEDIUM and FINE controls vary the reference voltage for galvanometer balance.
10	MODE	S 801	Selects SEARCH or TRANSFER modes for either AC or DC input to the instrument. Range selection is made in the SEARCH modes by selecting a voltage range that gives a PERCENT INPUT meter indication between 50% and 100%. The TRANSFER positions connect the selected range to the thermocouple. Transfers may be made at inputs below 50% but sensitivity will diminish. Should an overload occur, the Model 540B may be reset by switching the mode switch to OFF and then back to the desired mode.
11	RANGE	S 501	Selects the proper dropping resistor and compensating network for measurements of voltages up to and including the voltage indicated (dc or ac rms). The SHUNT position is used with Fluke Model A40 Current Shunts.
12	POLARITY	S 802	Is used to reverse the input to the thermocouple to facilitate the measurement of the turn-over error of the thermocouple.

Figure 2-2. FRONT-PANEL CONTROLS, TERMINALS, AND INDICATORS (Sheet 1 of 2)

REF NR.	NAME	REF DESIG	FUNCTION
13	SHUNT	J 805 J 806	Binding posts provided to accept the Fluke Model A40 Current Shunts. A locking screw for the larger shunts is provided and is located on the rear panel of the Model A54 plug-in unit. Without a Model A40 plug-in the instrument has a basic current range of 2.5 to 5 ma.
14	DC INPUT	J 801 J 803	Binding posts, with centers 3/4 inch apart, are provided for connecting dc voltage to the A54. Connect the positive lead to the upper post. The lower post is chassis ground.
15	AC INPUT	J 802 J 804	A dual purpose AC INPUT connector arrangement is provided in the Model A54. AC voltages may be applied to the unit through the UHF type connector or, since a separate ground post is located 3/4 inch from the UHF connector's center, a standard dual banana plug.
16	PROTECTION DISABLE (Model A54-2 only)	S 803	Disconnects the diode protection circuit in parallel with the thermocouple, when depressed. Depression of the switch, while at null (zero) on the GALVANOMETER meter in the AC TRANSFER mode, will cause a deflection. If the deflection at each frequency and on each range of interest is noted periodically, the change in deflection will then be an indication of the long term stability performance of the transfer portion of the unit including the protective circuitry.
17	PANEL BUSHING	NONE	An internally threaded bushing used in conjunction with the current shunt retaining screw.

Figure 2-2. FRONT-PANEL CONTROLS, TERMINALS, AND INDICATORS (Sheet 2 of 2)

2-5. Should lesser degrees of accuracy suffice for any application, the specifications for auxiliary equipment as shown in Figure 2-3 may be reduced. For additional application information contact your Fluke representative or the factory.

2-6. METHODS OF OPERATION

2-7. There are many different methods of making accurate transfer measurements. The methods outlined in this manual are suggested as being adequate. Information about transfer measurements, methods, theory, etc. may be found in the following references:

- a. THERMAL CONVERTERS AS AC-DC TRANSFER STANDARDS FOR CURRENT AND VOLTAGE MEASUREMENTS AT AUDIO FREQUENCIES, F. L. Hermach, J. Research 48, 121 (1952) RP2296.
- b. A WIDE-RANGE VOLT-AMPERE CONVERTER FOR CURRENT AND VOLTAGE MEASUREMENTS, AIEE Transactions, Communications and Electronics, Paper No. 59-161 (1959). F. L. Hermach and E. S. Williams.
- c. CALIBRATION OF VOLT-AMPERE CONVERTERS, National Bureau of Standards Technical Note 188, (1963) E. S. Williams.

2-8. PRELIMINARY OPERATION

2-9. PRECAUTIONS

2-10. High order accuracy can be obtained with this Transfer Standard only if the user is aware of certain limitations and takes appropriate precautions as follows:

- a. Bead type thermocouples, like that used in the Model 540B, exhibit a small exponentially decreasing drift of emf after a steady heater current is initially applied. Allow approximately 10 minutes for the thermocouple element to stabilize. After the stabilization time, the drift should be less than 2 small divisions per minute in the HIGH sensitivity position. When changing to different levels of input, after the stabilization period, a wait of only a few minutes is necessary before continuing with measurements. Any observed drift should be evaluated quantitatively.
- b. Connection errors should be evaluated and minimized when the Transfer Standard is used to calibrate other instruments. These errors can often be detected by changing the length and position of the leads. Short coaxial leads should be used when possible. These errors can be significant at high test frequencies.

FUNCTION	SPECIFICATIONS DESIRED FOR MAXIMUM ACCURACY	APPLICATION	RECOMMENDED INSTRUMENT
AC Voltage Source	AMPLITUDE STABILITY: .01% short term. AMPLITUDE RESOLUTION: .002% at desired output voltage. OUTPUT VOLTAGE: 0.225 to 1000 volts. OUTPUT CURRENT: 5 to 10 ma. FREQUENCY: Dependent on application.	Supplying an ac voltage for setting up a calibrated ac voltage and measuring frequency response of voltage indicating instruments and voltage amplifiers.	No one ac source will meet the specifications desired for maximum accuracy over the frequency range covered. AC signal sources and amplifiers that will give satisfactory results in most applications are made by Boonton Radio Corp., Hewlett Packard, Holt Inst. Lab., Krohn-Hite, Optimization, Rohde and Schwarz, and Tektronix Inc.
DC Voltage Source	AMPLITUDE STABILITY: .002% short term. AMPLITUDE RESOLUTION: .002% at desired output. OUTPUT VOLTAGE: 0.225 to 1000 volts. OUTPUT CURRENT: 5 to 10 ma.	Supplying the dc voltage equal to the rms value of the ac voltage to be measured.	John Fluke Model 332A Voltage Calibrator, which has the additional feature in calibration accuracy of .003% which would eliminate the requirement for DC voltage measuring equipment in many cases.
Dc Voltage Measuring Equipment	RANGE: 0.225 to 1000 volts. ACCURACY: .003%.	Accurate calibration of the dc source.	John Fluke Model 885A Differential Voltmeter offers adequate accuracy and stability for use in this system.
AC Current Source	AMPLITUDE STABILITY: .01% short term. AMPLITUDE RESOLUTION: .002% at desired output current. OUTPUT CURRENT: 2.5 ma to 20 amperes. OUTPUT VOLTAGE: Approximately 1v in excess of the voltage required by the network under test. FREQUENCY: Dependent on the application.	Supplying an ac current for setting up a calibrated ac current and measuring frequency response of current measuring devices.	In most cases it will be necessary to use a variable voltage source and an appropriate resistor.
DC Current source	AMPLITUDE STABILITY: .002% short term. AMPLITUDE RESOLUTION: .002% at desired output current. OUTPUT CURRENT: 2.5 ma to 20 amperes. OUTPUT VOLTAGE: Approximately 1v in excess of the voltage required by the network under test.	Supplying the dc current equal to the rms value of the ac current to be calibrated or measured.	In most cases it will be necessary to use a variable voltage source and an appropriate resistor. For many applications, the Fluke Model 382A Voltage/Current Calibrator will be very useful.
DC Current Measuring Equipment	RANGE: 2.5 ma to 20 amperes. ACCURACY: .01%. STABILITY: .01% short term.	Accurate measurement of the dc current flow.	Use a standard resistor and the dc voltage measuring equipment previously recommended. If the Fluke Model 382A Voltage/Current Calibrator is used current measuring equipment will not be needed within the calibrator range.
AC Current Measuring Equipment	RANGE: 2.5 ma to 20 amperes. ACCURACY: 10%.	Approximate current measurement to prevent shunt damage.	Use common commercial ammeter.

Figure 2-3. 540B AUXILIARY EQUIPMENT LIST

- c. Radio Frequency Interference can be particularly troublesome with low-current thermoelements. The thermocouple in the Model 540B is incased in a steel shield to minimize stray field pick-up. However, to insure accuracy, the Model 540B should be used in areas of relatively low field strength.
- d. The number of transfers will vary with the degree of accuracy required. In general it is suggested that three seperate transfers (dc to ac and back to dc constitutes one transfer) be made for any single measurement. This will be adequate only if a good degree of repeatability is achieved. Difficulty in repeating any measurement can be caused by any number of problems, the most common of which are poor connections, unstable sources, and interference from stray capacitance or energy fields. Any factor which detracts from repeatability must be eliminated before accurate transfers can be made.
- e. All of the components and elements in the Model 540B have been selected to minimize environmental sensitivity. It is suggested that the Model 540B be given time enough to arrive at the environmental temperature before it is used. If the Model 540B is used before it has arrived at the temperature of the environment where it is to be used,excessive thermal drift will be observed making accurate transfers more difficult.
- f. The Model 540B imposes two load conditions on the ac source. The ac source sees the 182 ohms/volt input impedance of the Model 540B when the MODE switch is in the AC TRANSFER position. When the MODE switch is in the OFF or DC TRANSFER positions, the ac source sees the Model 540B as an open circuit. This impedance change across the ac source causes a corresponding output level change from the ac source. When calibrating a device that is quite sensitive to level changes, the user should determine if the ac source level changes could adversely affect the device. The user should take appropriate precautions, such as switching the device out of the calibration circuit before turning the MODE switch to the OFF or DC positions, should such a situation arise.
- g. Though the internal range selection components and thermocouple in the Model 540B are protected from overloads in the voltage mode; no protection is provided in the current mode or for external shunts or high frequency converters. These devices are easily damaged or destroyed by overloads and all

possible precautions should be observed. External switching transients cause many such overloads and should be avoided. It is possible to damage a thermal converter without completely destroying it. One of the characteristics which change, and indicate a damaged thermal element, is dc reversal error. Should the reversal error of any thermal element change after a suspected overload it is reasonable to assume that damage has occurred and the device should be recalibrated.

- h. During all transfer measurements the operator must remain alert to changes in readings regardless of their cause. All such changes should be analyzed and corrective measures taken, in order to insure the accuracy of the transfer measurements.

2-11. BATTERY CHECK

2-12. Use the procedure of Figure 2-4 to check for sufficient battery charge each time the instrument is used.

2-13. DEFLECTION SENSITIVITY

2-14. To determine the percentage represented by the GALVANOMETER at a desired dc voltage or current level applied to the DC INPUT terminals, use the procedure of Figure 2-5.

2-15. DC REVERSAL ERROR

2-16. The measurement technique used in the following procedures does not utilize the dc reversal error as expressed in percent change. However, it is recommended that a dc reversal error check be made and recorded for future reference, in event that suspected overload damage has occurred to the thermocouple. This value can be used for comparison, as discussed in step g of paragraph 2-10. The amount of dc reversal error at a particular input level may be measured as follows:

- a. Apply the desired dc voltage or current to the A54 DC INPUT terminals. Determine the deflection sensitivity in the HIGH SENSITIVITY position as described in Figure 2-5.
- b. Adjust the REFERENCE ADJUST controls until a GALVANOMETER indication of zero is obtained in the HIGH SENSITIVITY position.
- c. Set the GALV switch to OPEN. Depress the POLARITY switch until it locks and remains in the depressed position. Wait approximately 5 seconds; then place the GALV switch in the LOCK position.

STEP	CONTROL	POSITION	OPERATION
a	POWER	REFERENCE GALVO SEARCH	The PERCENT INPUT meter must read above the lower limit of the BAT band on the meter scale in all BAT CHECK positions.

Figure 2-4. BATTERY CHECK

STEP	CONTROL	POSITION	OPERATION
a	POWER GALV RANGE MODE	ON OPEN 1000v DC SEARCH	Set the RANGE switch to succeeding lower voltage ranges until an indication between 50% and 100% is obtained on the PERCENT INPUT meter. When using current shunts see paragraph 2-24.
b	SENSITIVITY MODE GALV REFERENCE ADJUST	LOW DC TRANSFER → COARSE MEDIUM	Tap the GALV switch against the spring tension to MOMENTARY just long enough to see if the GALVANOMETER needle will stay on scale. Adjust the COARSE and MEDIUM controls until a zero reading is obtained.
c	GALV SENSITIVITY GALV ZERO	OPEN MED →	Adjust the GALV ZERO control for a zero reading on the GALVANOMETER.
d	GALV REFERENCE ADJUST	LOCK MEDIUM	Adjust the MEDIUM and FINE controls for a zero reading on the GALVANOMETER.
e	SENSITIVITY TEST	0.1%	<p>The GALVANOMETER will deflect to the right by an amount equal to a 0.1% change in input level. This deflection amount may be used to determine the deflection sensitivity (percent per unit of deflection), which in turn may be used to determine the percent change represented by an on scale GALVANOMETER deflection as follows:</p> $\text{Deflection Sensitivity} = \frac{0.1\%}{D_t}$ $\% \text{ Change} = \frac{0.1\%}{D_t} D_m$ <p>D_t = The number of divisions of meter deflection caused by the operation of the SENSITIVITY TEST switch.</p> <p>D_m = The number of divisions of meter deflection found in the transfer measurement.</p>
f	SENSITIVITY TEST GALV SENSITIVITY GALV ZERO	OPR OPEN HIGH →	Adjust the GALV ZERO control for a zero reading on the GALVANOMETER.
g	GALV REFERENCE ADJUST	LOCK FINE	Adjust the FINE control for a zero reading on the GALVANOMETER.
h	SENSITIVITY TEST	0.01%	<p>The GALVANOMETER will deflect to the right by an amount equal to a 0.01% change in input level. This deflection amount may be used to determine the deflection sensitivity (percent per unit of deflection), which in turn may be used to determine the percent change represented by an on scale GALVANOMETER deflection as follows:</p> $\text{Deflection Sensitivity} = \frac{0.01\%}{D_t}$ $\% \text{ Change} = \frac{0.01\%}{D_t} D_m$
NOTE: Deflection sensitivity is improved as the level of input more nearly equals the range setting.			

Figure 2-5. DEFLECTION SENSITIVITY

STEP	CONTROL	POSITION	OPERATION
a	POWER GALV SENSITIVITY RANGE MODE	ON OPEN LOW 1000v AC SEARCH	Set the RANGE switch to successively lower voltage ranges until an indication between 50% and 100% is obtained on the PERCENT INPUT meter. (Better transfer resolution is obtained with readings closer to 100%.)
b	SENSITIVITY MODE GALV REFERENCE ADJUST	LOW AC TRANSFER COARSE MEDIUM	Tap the GALV switch against the spring tension to MOMENTARY just long enough to see if the GALVANOMETER needle will stay on scale. Adjust the COARSE and MEDIUM controls until a zero reading is obtained.
c	GALV SENSITIVITY GALV ZERO	OPEN MED	Adjust the GALV ZERO control for zero reading on the GALVANOMETER.
d	GALV REFERENCE ADJUST	LOCK MEDIUM FINE	Adjust the MEDIUM and FINE controls for zero reading on the GALVANOMETER.
e	GALV SENSITIVITY GALV ZERO	OPEN HIGH	Adjust the GALV ZERO control for zero reading on the GALVANOMETER.
f	GALV REFERENCE ADJUST	LOCK FINE	Adjust the FINE control for a zero reading on the GALVANOMETER.
g	GALV SENSITIVITY	OPEN LOW	
h	MODE	DC SEARCH	Adjust the dc source voltage until a reading is obtained on the PERCENT INPUT meter that is equal to the reading noted in step a.
i	MODE	DC TRANSFER	NOTE: DO NOT ADJUST THE REFERENCE ADJUST CONTROLS IN THIS MODE.
j	SENSITIVITY GALV	LOW	Tap the GALV switch against the spring tension to MOMENTARY just long enough to see if the GALVANOMETER needle will stay on scale. Adjust the dc source voltage until zero is obtained.
k	GALV SENSITIVITY	LOCK MEDIUM HIGH	Further refine the adjustment of the dc source voltage until zero reading on the GALVANOMETER is obtained in the HIGH SENSITIVITY position.
l	Record the exact dc source voltage.		
m	Repeat steps b through l at least three times or until repeatability is attained. Record the exact dc voltage.		
n	Reverse the input polarity to the thermocouple by depressing the POLARITY switch. Repeat steps b through l at least three times or until repeatability is attained. Record the exact dc voltage.		
o	The rms value of the unknown ac voltage is equal to the average of the two dc voltages recorded in steps l and n.		
<p>NOTE: If a test report from a standards laboratory is used, calculate the unknown ac voltage from the following equation:</p> $E_{ac} = \left(1 + \frac{a_o}{100}\right) E_{dc}$ <p>Where: E_{dc} = average of two dc voltages recorded</p> $a_o = \frac{E_{ac} - E_{dc}}{E_{dc}} \times 100 = \text{ac to dc percent difference from the test report}$			

Figure 2-6. MEASURING AN UNKNOWN AC VOLTAGE

- d. The resulting GALVANOMETER deflection indicates the amount of dc reversal error. The percent change may be computed by multiplying the deflection sensitivity determined in step a by the amount of dc reversal error.
- e. Set the GALV switch to OPEN. Set the POLARITY switch to its normal, up, position.

2-17. VOLTAGE MEASUREMENT AND CALIBRATION

2-18. MEASURING AN UNKNOWN AC VOLTAGE

2-19. Complete the Battery Check of Figure 2-4. With the RANGE switch in the 1000 volt position and the MODE switch set to OFF, connect the ac voltage to the AC INPUT terminals and the dc source to the DC INPUT terminals. Use the procedure of Figure 2-6.

2-20. CALIBRATING AN AC VOLTAGE SOURCE

2-21. Complete the Battery Check of Figure 2-4. With the RANGE switch in the 1000 volt position and the MODE switch set to OFF, connect the ac source to the AC INPUT terminals and the dc source to the DC INPUT terminals. Follow the procedure of Figure 2-7, for the calibration of an ac voltage source.

Note!

If a test report from a standards laboratory is used, adjust the dc source voltage in step a to equal $\frac{100}{100 + a_0}$ times the rms value of

the ac voltage to be calibrated. Where a_0 is the ac to dc percent difference from the test report.

2-22. CURRENT MEASUREMENT AND CALIBRATION

2-23. GENERAL

2-24. A current shunt will not be required if the current to be measured or calibrated is 2.5 to 5 milliamperes. The thermocouple of the Model A54 is capable of handling this amount of current.

2-25. Current shunts rated up to 30 milliamperes are plugged directly into the SHUNT terminals of the Model A54. Current shunts from 50 milliamperes to 5 amperes are also plugged directly into the SHUNT terminals of the Model A54. However, a special retaining screw (located on the rear panel of the Model A54) is used to secure these larger current shunts to the front panel of the Model A54. The Fluke Model A40A Current Shunts, 10 and 20 ampere, are connected to the Model A54 with a special cable (Fluke part number 6002-212860, illustrated in Figure 6-4).

2-26. To eliminate the process of interchanging the ac and dc leads to a current shunt, the Fluke Model A45 Current Transfer Switch may be used. Proper cables and connections to current shunts in conjunction with the Models A54 and A45 are illustrated in Figure 2-8.

2-8

2-27. Two precautions in regard to lead length and effects of the Model A45 upon a voltage source should be considered.

- a. To minimize errors from induced voltages when connecting a current shunt or Model A45 to a circuit under test, use a coaxial cable 30 centimeters or less in length.
- b. Due to the shorting type transfer switch of the Model A45, a current limiting resistor should be placed in series with a voltage source used as a current source. If the current limiting resistor is not used there is a possibility that the voltage source could be damaged.

2-28. MEASURING AN UNKNOWN AC CURRENT

2-29. Complete the Battery Check of Figure 2-4. With a common commercial ammeter, measure the unknown current in order to select the proper Model A40 or Model A40A Current Shunt. If determination of deflection sensitivity is desired, refer to Figure 2-5 and substitute step a with the following: MODE switch to OFF, RANGE switch to SHUNT, GALV switch to OPEN, and POWER switch to ON. Follow the procedure of Figure 2-9, for measurement of an unknown ac current.

Note!

The PERCENT INPUT meter of the Model 540B does not function in the current mode of operation.

CAUTION!

Protection from overload is not provided for the current shunts or the thermocouple of the Model A54 when in the SHUNT position of the RANGE switch (current mode of operation).

2-30. CALIBRATING AN AC CURRENT SOURCE

2-31. Complete the Battery Check of Figure 2-4. Refer to paragraph 2-23, for proper shunt selection and connections. The current shunt selected should be of the lowest value possible without exceeding the rated value. Observe the note and caution of paragraph 2-29. Use the procedure of Figure 2-10, for calibrating an ac current source.

Note!

If an A40 or A40A test report is used, adjust the dc source until the dc current equals $\frac{100}{100 + a_0}$ times the rms value of the ac current desired. Where a_0 is the ac to dc percent difference from the test report.

STEP	CONTROL	POSITION	OPERATION
a	POWER GALV SENSITIVITY RANGE MODE	ON OPEN LOW DC SEARCH	Set the RANGE switch in a position that will cause the PERCENT INPUT meter to indicate close to, but not exceed, 100% for the level to be calibrated. Adjust the dc source voltage to the exact rms value of the ac voltage to be calibrated. (Note PERCENT INPUT meter indication.)
b	MODE GALV REFERENCE ADJUST	DC TRANSFER COARSE MEDIUM	Tap the GALV switch against the spring tension to MOMENTARY just long enough to see if the GALVANOMETER needle will stay on scale. Adjust the COARSE and MEDIUM controls until a zero reading is obtained.
c	GALV SENSITIVITY GALV ZERO	OPEN MED	Adjust the GALV ZERO control for zero reading on the GALVANOMETER.
d	GALV REFERENCE ADJUST	LOCK MEDIUM FINE	Adjust the MEDIUM and FINE controls for zero reading on the GALVANOMETER.
e	GALV SENSITIVITY GALV ZERO	OPEN HIGH	Adjust the GALV ZERO control for a zero reading on the GALVANOMETER.
f	GALV REFERENCE ADJUST	LOCK FINE	Adjust the FINE control for a zero reading on the GALVANOMETER.
g	GALV SENSITIVITY	OPEN LOW	
h	MODE	AC SEARCH	Adjust the ac level to be calibrated until a reading is obtained on the PERCENT INPUT meter that is equal to the reading obtained and noted in step a.
i	MODE	AC TRANSFER	NOTE: DO NOT ADJUST THE REFERENCE ADJUST CONTROLS IN THIS MODE.
j	SENSITIVITY GALV	LOW	Tap the GALV switch against the spring tension to MOMENTARY just long enough to see if the GALVANOMETER needle will stay on scale while adjusting the level of the ac to be calibrated. When an on scale reading is obtained adjust the ac level for a zero reading on the GALVANOMETER.
k	GALV SENSITIVITY	LOCK MED HIGH	Further refine the adjustment of the ac voltage until a GALVANOMETER reading of zero is obtained in the MED and HIGH SENSITIVITY positions. Record the ac voltage source setting.
l	Repeat steps b through k at least three times or until repeatability is attained. Make note of the ac source setting.		
m	Reverse the input polarity to the thermocouple by depressing the POLARITY switch. Repeat steps b through k at least three times or until repeatability is attained. Make note of the ac source setting.		
n	Set the ac source voltage adjustment in the center of the two settings recorded in steps l and m. The rms value of the ac voltage now equals that desired.		

Figure 2-7. CALIBRATING AN AC VOLTAGE SOURCE

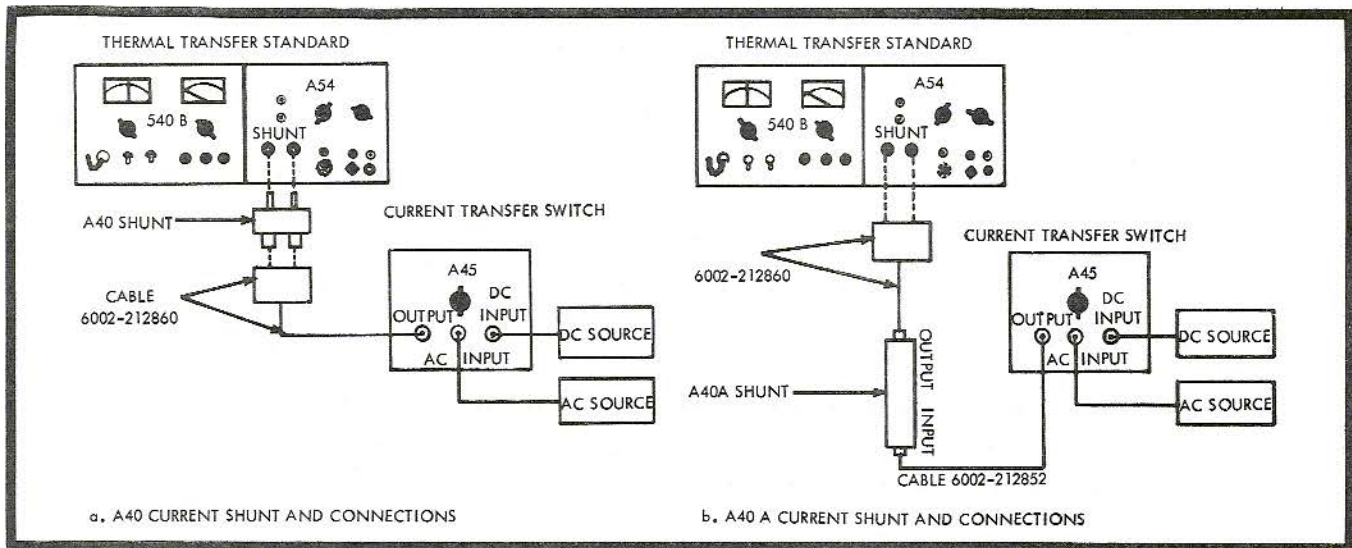

Figure 2-8. CABLES AND CONNECTIONS FOR CURRENT SHUNTS

2-32. HIGH FREQUENCY VOLTAGE MEASUREMENT AND CALIBRATION

2-33. GENERAL

2-34. A special cable, supplied with the Model 540B, provides a means of connecting the output of an external thermal converter to the HIGH FREQ CONVERTER jack on the front panel of the Model 540B for high frequency ac voltage measurements. The Fluke Model A55 Thermal Converter series of nine high frequency thermal converters are supplied in ranges identical with the Model 540B ranges up to and including 50 volts. These converters make accurate measurements up to 50 MHz possible. When using external thermal converters the internal thermocouple, range switch, transfer switch, search and protection circuits are not used. Since no protection is provided for the external thermal converter it will be necessary to use all normal cautions to avoid overloads. The instruction manual for the A55 Thermal Converters should be used to obtain the correction factor due to transmission line effects.

CAUTION!

Always use a thermal converter whose rated value is equal to or greater than the rms value of the ac voltage to be measured. If the approximate value of the ac voltage is unknown, measure with a high frequency voltmeter before connecting to the thermal converter.

2-35. MEASURING AN UNKNOWN HIGH FREQUENCY VOLTAGE

2-36. Complete the Battery Check of Figure 2-4. Remove the plug from the HIGH FREQ CONVERTER jack on the Model 540B. Connect the selected Model A55 Thermal Converter output to the HIGH FREQ CONVERTER jack using the interconnecting cable, supplied

2-10

with the Model 540B. This cable allows the external converter to be connected close to the ac being measured, thus reducing transmission line effects. Connect the thermal converter to the ac source to be measured. The voltage may be 1/2 to 1 times the rated value of the converter. Use the procedure in Figure 2-11.

Note!

Depending on how the Model A55 Thermal Converter is connected to the source of the unknown voltage, it may be necessary to make corrections for standing waves at frequencies above 5 MHz. See the Model A55 Thermal Converter manual for further information.

2-37. CALIBRATING A HIGH FREQUENCY VOLTAGE SOURCE

2-38. Complete the Battery Check of Figure 2-4. Remove the plug from the HIGH FREQ CONVERTER jack on the Model 540B front panel. Connect the selected Model A55 Thermal Converter output to the HIGH FREQ CONVERTER jack using the interconnecting cable, supplied with the Model 540B. This cable allows the external converter to be connected close to the ac being calibrated, thus reducing transmission line effects. Connect the thermal converter to the ac source to be calibrated. The voltage may be 1/2 to 1 times the rated value of the converter. Use the procedure in Figure 2-12.

Note!

If the input impedance of the instrument being calibrated is not 50 ohms, it may be necessary to correct for the standing wave between the center of the tee and the instrument being calibrated at frequencies above 5 MHz. See the Model A55 Thermal Converter manual for further information.

STEP	CONTROL	POSITION	OPERATION
a	RANGE POWER SENSITIVITY MODE GALV REFERENCE ADJUST	SHUNT ON LOW OFF → COARSE MEDIUM	Connect ac source under test or, if using the A45 Transfer Switch, set the OUTPUT MODE switch to AC. Tap the GALV switch against the spring tension to MOMENTARY just long enough to see if the GALVANOMETER needle will stay on scale. Adjust the COARSE and MEDIUM REFERENCE ADJUST controls until a reading is obtained.
b	GALV SENSITIVITY GALV ZERO	OPEN MED →	Adjust the GALV ZERO control for zero reading on the GALVANOMETER.
c	GALV REFERENCE ADJUST	LOCK MEDIUM FINE	Adjust the MEDIUM and FINE controls for a zero reading on the GALVANOMETER.
d	GALV SENSITIVITY GALV ZERO	OPEN HIGH →	Adjust the GALV ZERO control for zero reading on the GALVANOMETER.
e	GALV REFERENCE ADJUST	LOCK FINE	Adjust the FINE control for a zero reading on the GALVANOMETER.
f	GALV SENSITIVITY	OPEN LOW	Disconnect the ac circuit under test from the current shunt and connect the dc current source, using care not to exceed the current rating of the shunt. If using the A45 Transfer Switch, set the OUTPUT MODE switch to DC.
g	GALV	→	Tap the GALV switch against the spring tension to MOMENTARY just long enough to see if the GALVANOMETER needle will stay on scale while slowly increasing the dc source current until zero is reached on the GALVANOMETER. Do not adjust the REFERENCE ADJUST controls in this mode.
h	GALV SENSITIVITY	LOCK MED HIGH	Further refine the adjustment of dc current source to maintain a zero reading on the GALVANOMETER in the MED and HIGH sensitivity positions.
i	GALV	OPEN	Disconnect the dc source and connect the ac current to be measured to the shunt. If using the A45 Transfer Switch, set the OUTPUT MODE switch to AC.
j	GALV	LOCK	Readjust the REFERENCE ADJUST FINE control for zero on the GALVANOMETER.
k	GALV	OPEN	Disconnect the ac current under test and reconnect the dc source to the shunt. If using the A45 Transfer Switch, set the OUTPUT MODE switch to DC.
l	GALV	LOCK	Adjust the dc current source to maintain a zero reading on the GALVANOMETER. Measure and record the dc current.
m	Repeat steps i through l at least three times or until repeatability is attained. Measure and record the dc current.		
n	Reverse the input polarity to the thermocouple by depressing the POLARITY switch. Repeat steps i through l at least three times or until repeatability is attained. Measure and record the dc current.		
o	The rms value of unknown ac current is equal to the average of the two dc currents recorded in steps m and n.		
NOTE: If a test report from a standards laboratory is used, calculate the unknown ac current from the following equation:			
$I_{ac} = \left(1 + \frac{a_o}{100}\right) I_{dc}$			
Where:			
$I_{dc} = \text{average value of the two dc currents from step o.}$			
$a_o = \frac{I_{ac} - I_{dc}}{I_{dc}} \times 100 = \text{ac to dc percent difference from the test report.}$			

Figure 2-9. MEASURING AN UNKNOWN AC CURRENT

STEP	CONTROL	POSITION	OPERATION
a	RANGE POWER SENSITIVITY MODE GALV REFERENCE ADJUST	SHUNT ON → LOW OFF COARSE MEDIUM	Set the OUTPUT MODE switch to DC, if using the A45 Transfer switch. Adjust the dc source until the dc current exactly equals the rms value of the ac current to be calibrated. Tap the GALV switch against the spring tension to MOMENTARY just long enough to see if the GALVANOMETER needle will stay on scale. Adjust the COARSE AND MEDIUM REFERENCE ADJUST controls until a zero reading is obtained.
b	GALV SENSITIVITY GALV ZERO	OPEN MED →	Adjust the GALV ZERO control for zero reading on the GALVANOMETER.
c	GALV REFERENCE ADJUST	LOCK MEDIUM FINE	Adjust the MEDIUM and FINE controls for a zero reading on the GALVANOMETER.
d	GALV SENSITIVITY GALV ZERO	OPEN HIGH →	Adjust the GALV ZERO control for zero reading on the GALVANOMETER.
e	GALV REFERENCE ADJUST	LOCK FINE	Adjust the FINE control for a zero reading on the GALVANOMETER.
f	GALV SENSITIVITY	OPEN LOW	Disconnect the dc source from the shunt and connect the ac to be calibrated to it. If using the A45 Transfer Switch set the OUTPUT MODE switch to AC.
g	GALV	→	Tap the GALV switch against the spring tension to MOMENTARY just long enough to see if the GALVANOMETER needle will stay on scale while adjusting the level of the ac to be calibrated. Repeat until a zero reading is obtained. Do not adjust the REFERENCE ADJUST controls in this mode.
h	GALV SENSITIVITY	LOCK MED HIGH	Further refine the level adjustment of the ac to be calibrated for a zero reading on the GALVANOMETER in the MED and HIGH sensitivity positions.
i	GALV	OPEN	Disconnect the ac being calibrated and reconnect the dc source. If using the A45 Transfer Switch, set the OUTPUT MODE switch to DC.
j	GALV	LOCK	Readjust the FINE REFERENCE control for zero reading on the GALVANOMETER.
k	GALV	OPEN	Disconnect the dc source from the shunt input and reconnect the ac to be calibrated. If using the A45 Transfer Switch, set the OUTPUT MODE switch to AC.
l	GALV	LOCK	Adjust the ac current to be calibrated to maintain zero on the GALVANOMETER. Record ac current source setting.
m	Repeat steps i through l at least three times or until repeatability is attained. Record the ac current source setting.		
n	Reverse the input polarity to the thermocouple by depressing the POLARITY switch. Repeat steps i through l at least three times or until repeatability is attained. Record the ac current source setting.		
o	Set the ac current source adjustment in the center of the two settings recorded in steps m and n. The rms value of the ac current now equals that desired.		

Figure 2-10. CALIBRATING AN AC CURRENT SOURCE

STEP	CONTROL	POSITION	OPERATION
a	SENSITIVITY POWER GALV REFERENCE ADJUST	LOW ON → COARSE MEDIUM	Tap the GALV switch against the spring tension to MOMENTARY just long enough to see if the GALVANOMETER needle will stay on scale while adjusting the COARSE and MEDIUM REFERENCE ADJUST controls. Repeat until a zero reading is obtained.
b	GALV SENSITIVITY GALV ZERO	OPEN MED →	Adjust the GALV ZERO control for zero reading on the GALVANOMETER.
c	GALV REFERENCE ADJUST	LOCK MEDIUM FINE	Using the MEDIUM and FINE REFERENCE ADJUST controls, zero the GALVANOMETER needle.
d	GALV SENSITIVITY GALV ZERO	OPEN HIGH →	Adjust the GALV ZERO control for zero reading on the GALVANOMETER
e	GALV REFERENCE ADJUST	LOCK FINE	Using the FINE REFERENCE ADJUST controls, zero the GALVANOMETER. Do not use the REFERENCE ADJUST controls except to null the ac being measured.
f	GALV	OPEN	Disconnect the external converter from the ac being measured and connect it to the dc standard source, being careful not to exceed the rated value of the external converter. Adjust the dc source to the approximate rms value of the ac to be measured.
g	SENSITIVITY GALV	LOW →	Tap the GALV switch against the spring tension to MOMENTARY just long enough to see if the GALVANOMETER needle will stay on scale, while adjusting the dc source voltage. Repeat until a zero reading is obtained.
h	SENSITIVITY GALV	MED HIGH LOCK	Further refine the adjustment of the dc source to maintain a zero reading on the GALVANOMETER in the MED and HIGH SENSITIVITY positions.
i	GALV	OPEN	Disconnect the external converter from the dc source and reconnect it to the ac being measured.
j	GALV REFERENCE ADJUST	LOCK FINE	Zero the GALVANOMETER with the FINE control.
k	GALV	OPEN	Disconnect the external converter from the ac being measured and connect it to the dc source.
l	GALV	LOCK	Refine the adjustment of the dc source to obtain a zero reading on the GALVANOMETER. (note level)
m	Repeat steps i through l at least three times or until repeatability is attained. Record the dc level		
n	Reverse the polarity of the dc source and repeat steps i through l at least three times or until repeatability is attained. Record the dc level.		
o	The rms value of the unknown ac voltage is equal to the average of the two dc voltages recorded in steps m and n.		

Figure 2-11. MEASURING AN UNKNOWN HF VOLTAGE

STEP	CONTROL	POSITION	OPERATION
a	SENSITIVITY REFERENCE ADJUST POWER GALV	LOW COARSE MEDIUM ON →	Connect the thermal converter to a calibrated dc source voltage equal to the rms value of the ac to be calibrated. Tap the GALV switch against the spring tension to MOMENTARY just long enough to see if the GALVANOMETER needle will stay on scale, while adjusting the COARSE and MEDIUM REFERENCE ADJUST controls until zero reading is obtained.
b	GALV SENSITIVITY GALV ZERO	OPEN MED →	Adjust the GALV ZERO control for zero reading on the GALVANOMETER.
c	GALV REFERENCE ADJUST	LOCK MEDIUM FINE	Using the MEDIUM and FINE REFERENCE ADJUST controls, zero the GALVANOMETER needle.
d	GALV SENSITIVITY GALV ZERO	OPEN HIGH →	Adjust the GALV ZERO control for zero reading on the GALVANOMETER.
e	GALV REFERENCE ADJUST	LOCK FINE	Using the FINE REFERENCE ADJUST control, zero the GALVANOMETER needle. Do not use the REFERENCE ADJUST controls except to zero the dc source voltage.
f	GALV	OPEN	Disconnect the dc source voltage from the external converter and connect the ac voltage to be calibrated. Use caution not to exceed the voltage rating of the converter.
g	SENSITIVITY GALV	LOW →	Tap the GALV switch against the spring tension to MOMENTARY just long enough to see if the GALVANOMETER needle will stay on scale, while adjusting the level of the ac voltage to be calibrated. Repeat until a zero reading is obtained.
h	GALV SENSITIVITY	LOCK MED HIGH	Further refine the adjustment of the ac voltage being calibrated until a zero reading on the GALVANOMETER needle is obtained in the MED and HIGH SENSITIVITY positions.
i	GALV	OPEN	Disconnect the external converter from the ac being calibrated and connect it to the dc standard source.
j	GALV REFERENCE ADJUST	LOCK FINE	Zero the GALVANOMETER needle with the FINE REFERENCE ADJUST control.
k	GALV	OPEN	Disconnect the external converter from the dc standard and connect it to the ac voltage being calibrated.
l	GALV	LOCK	Refine the adjustment of the ac voltage being calibrated for zero reading on the GALVANOMETER.
m	Repeat steps i through l at least three times or until repeatability is attained. Record the ac voltage setting.		
n	Reverse the polarity of the dc source and repeat steps i through l at least three times or until repeatability is attained. Record the ac voltage setting.		
o	Set the ac source voltage adjustment in the center of the two settings recorded in steps m and n. The rms value of the ac voltage now equals that desired.		

Figure 2-12. CALIBRATING A HF VOLTAGE SOURCE

SECTION III

THEORY OF OPERATION

3-1. INTRODUCTION

3-2. The theory of operation is explained in this section with the aid of simplified diagrams. The general over-all description is followed by a detailed description of each section of the instrument.

3-3. GENERAL

3-4. Refer to Figure 3-1, Model 540B Block Diagram. With the MODE switch in the AC SEARCH position, the input signal passes from the binding posts thru the MODE switch, through the first protection relay (K801) and to the Search Compensated Attenuator. The output of the attenuator is connected to another section of the MODE switch and to the Protection Amplifier. The signal path

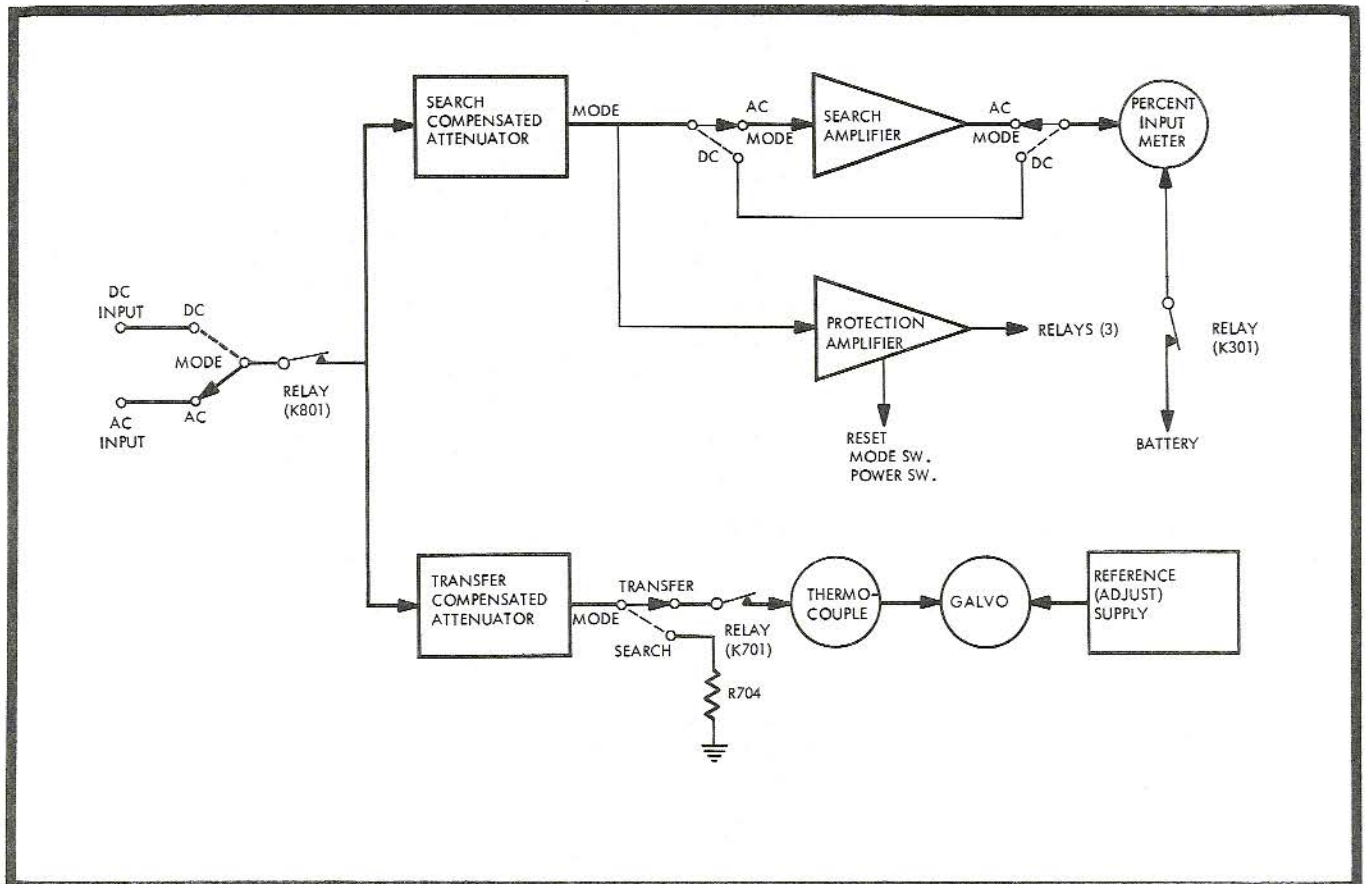

Figure 3-1. MODEL 540B BLOCK DIAGRAM

is thru the MODE switch to the Search Amplifier where the ac signal is amplified and then rectified and filtered. R704 is connected across the input in SEARCH to provide proper input impedance. The output of the Search Amplifier is then connected thru the MODE switch to the PERCENT INPUT meter where the needle deflection is calibrated to read in percentage of input per range selected.

3-5. When the MODE switch is in the DC SEARCH position the direct current path is identical with the ac path except that no amplification is required and the MODE switch provides an alternate path around the Search Amplifier. Calibration adjustments are provided for the search ranges in the Search Amplifier and in the alternate dc path around the Search Amplifier.

3-6. With the MODE switch in the AC or DC TRANSFER positions, the signal from the input terminals passes thru the MODE switch, then thru the first protection relay (K801), and feeds both Compensated Attenuators. The Search Compensated Attenuator output is connected to the Protection Amplifier and the Search Amplifier. The Transfer Compensated Attenuator feeds thru the MODE switch then thru the second protection relay (K701). From the second protection relay, the signal feeds the Thermocouple. The output of the Thermocouple is fed to the Galvanometer in such a manner that it is opposed or balanced by the output from the Reference Supply. The Galvanometer indicates the null or balance between the two.

3-7. The Protection Amplifier is always connected to the output of the Search Attenuator, and is designed to function on a pre-set level of ac or dc. When the Protection Amplifier operates it causes relays K701 and K801 to disconnect the input from the attenuators and open the circuit to the thermocouple. The Protection Amplifier also causes relay K301 to close a circuit from the battery supply which causes the PERCENT INPUT meter needle to deflect into the OVER LOAD area of the meter scale. Once the Protection Amplifier has operated it must be reset manually by turning the MODE switch to OFF. The cause of the overload should be located and removed and the range increased or other remedial action taken before returning the mode switch to its' operating position.

3-8. When the Model 540B is operated in the SHUNT mode, no protection is provided for either the Model 540B thermocouple or for the current shunt. It is necessary to exercise extreme caution when operating in this mode to prevent damage to the instrument.

3-9. CIRCUIT DESCRIPTIONS

3-10. SEARCH CIRCUIT

3-11. The search circuit is composed of three basic elements; the Search Compensated Attenuator, the Search Amplifier and the Percent Input Meter. The Search Compensated Attenuator is composed of switch S501E, R502 thru R514 and C501 thru C510. This attenuator is compensated to equalize the output of the Search Amplifier in order to give the Percent Input reading a favorable deflection/frequency response.

3-12. The Search Amplifier is a two stage transistor amplifier composed of Q301 and Q302 and the associated parts. Low frequency adjustment and calibration is accomplished with R310. High frequencies are calibrated with C305. CR301 and CR302 rectify the amplified ac and capacitors C303 and C304 filter the resultant dc voltage for application to the PERCENT INPUT meter. The Search Amplifier is not used in DC SEARCH and a path is provided by the MODE switch to apply dc directly to the meter from the attenuator.

3-13. PROTECTION CIRCUIT

3-14. The Protection Circuit is composed of an amplifier and two relays which interrupt current flow to the attenuators and the thermocouple, plus a set of diodes which provide additional protective features. It is characteristic of thermocouples to be able to withstand overloads of rather large magnitude for short periods of time. Diodes CR701 thru CR704 appear across the input of the A54 portion of the 540B and are biased in such a manner as not to conduct under normal operation. In the event of an overload, these diodes conduct and provide an alternate circuit, shunting the input to the thermocouple until the protection amplifier can operate the protection relays.

3-15. The protection amplifier is a single operation device designed to remain in a stable state until a voltage is applied to it that is in excess of the operating point. Once overloaded the amplifier operates the protection relays and holds them operated until power is removed from the protection amplifier. The three transistors in the Protection Amplifier are Q303, Q304 and Q305. Under normal (non overloaded) condition there is sufficient current flow thru Q305 to hold relays K701 and K801 in their operated positions. Transistors Q303 and Q304 are cut-off and remain so until the voltage across R313 raises to such a value as to start conduction. Once conduction is started, each transistor assists the other into faster saturation which lowers the voltage at the emitter of Q303. This emitter is connected to the base of Q305 and this voltage being lowered causes Q305 to cut-off releasing the protection relays by stopping the current flow to them. R314 is used to calibrate the operating point of the Protection Amplifier. The diode bridge composed of CR310 thru CR313 is used to protect the transistors of the Protection Amplifier from overloads and voltage surges which might damage them.

3-16. Other features of the protection circuit include the operation of K301 when the circuit is tripped. K301 supplies a fixed voltage to the PERCENT INPUT meter to indicate an over-load condition has occurred. Two diodes have been included in the protection circuit to "speed-up" the operation of the Protection Amplifier when moderate overloads occur. CR307 and CR314 present a low resistance path around R311 when ever the voltage drop across that resistor exceeds the conduction voltage of the diodes. Without these diodes, the time constant of R311 and C309 is sufficiently long to slow the operation of the Protection Amplifier enough to damage the thermocouple or other components under conditions of moderate overload, if the "speed-up" diodes were not provided.

3-17. Resetting the Protection Amplifier is accomplished by cutting off the voltage to it. It is always advisable to determine the cause of the overload before attempting to reset the circuit. The voltage may be cut-off to the Protection Amplifier by two methods. The MODE switch may be placed in the OFF position and the POWER switch may be operated to any position other than ON. Either of these actions will cause an interruption in the battery power to the Protection Amplifier. The preferred method is resetting the protection circuit with the MODE switch.

3-18. A push button, momentary open, switch called PROTECTION DISABLE is located on the front panel of the Model A54-2 plug-in unit. This switch, and its function, constitutes the only difference between the Model A54-1 and the Model A54-2 plug-in units. Depression of the PROTECTION DISABLE switch removes the diode circuit (CR701 thru CR704) in parallel with the thermocouple, providing a routine method of checking for diode leakage (see Section 4-31). The Model A54-2 is calibrated with the diode circuit active (PROTECTION DISABLE switch in the normal, up, position).

3-19. THERMOCOUPLE

3-20. The thermocouple element has been tested and selected at the factory and placed in an insulating case with a standard octal plug base. The thermocouple element is of the high vacuum, insulated type with a nominal output of 7 millivolts at rated input. The Model A54 unit will have to be rechecked for calibration accuracy if the thermocouple is replaced. The input to the thermocouple may be reversed by operating switch S802, POLARITY, located on the front panel of the Model A54 plug-in unit. With this switch it is possible to check the turn-over error of the thermocouple with a minimum of effort.

3-21. REFERENCE

3-22. When using the Transfer Standard it is not necessary to measure the output voltage of the thermocouple, it is necessary only to provide a means of detecting and comparing the thermocouple output accurately when making transfer measurements. A variable voltage source has been designed into the Model 540B which fulfills the stability and resolution requirements for this application. Referring to Figure 3-2, the adjustment of the REFERENCE ADJUST controls COARSE, MEDIUM and FINE will vary the voltage at point b, from zero to approximately 14 millivolts. The MOMENTARY position on the GALV switch makes it possible to search out and find an approximate null on the galvanometer with the COARSE control without applying a steady overload to the galvanometer. The LOCK position allows a fixed path for use while adjusting the MEDIUM and FINE controls to maintain the galvanometer balance in successively more sensitive ranges.

3-23. GALVANOMETER

3-24. Refer to Figure 3-3. When a dc voltage from the thermocouple and the reference supply is applied to the galvanometer circuit, the Magnetic Modulator (T2) produces a 5 kHz output containing magnitude and polarity information relative to the input dc. This 5 kHz signal is then applied to a Tuned Carrier Amplifier where the signal is amplified and undesirable frequencies are attenuated. The Tuned Carrier Amplifier output is then fed to the Synchronous Demodulator. The demodulator is a balanced demodulator that has no output when no signal is applied. The Push-Pull Oscillator and Frequency Doubler generates a 2.5 kHz signal that is fed to the Magnetic Modulator and a 5 kHz signal that is fed to the Synchronous Demodulator. With dc applied to the input of the Magnetic Modulator, a dc current flows thru the meter which is proportional in magnitude and like in polarity to the input dc.

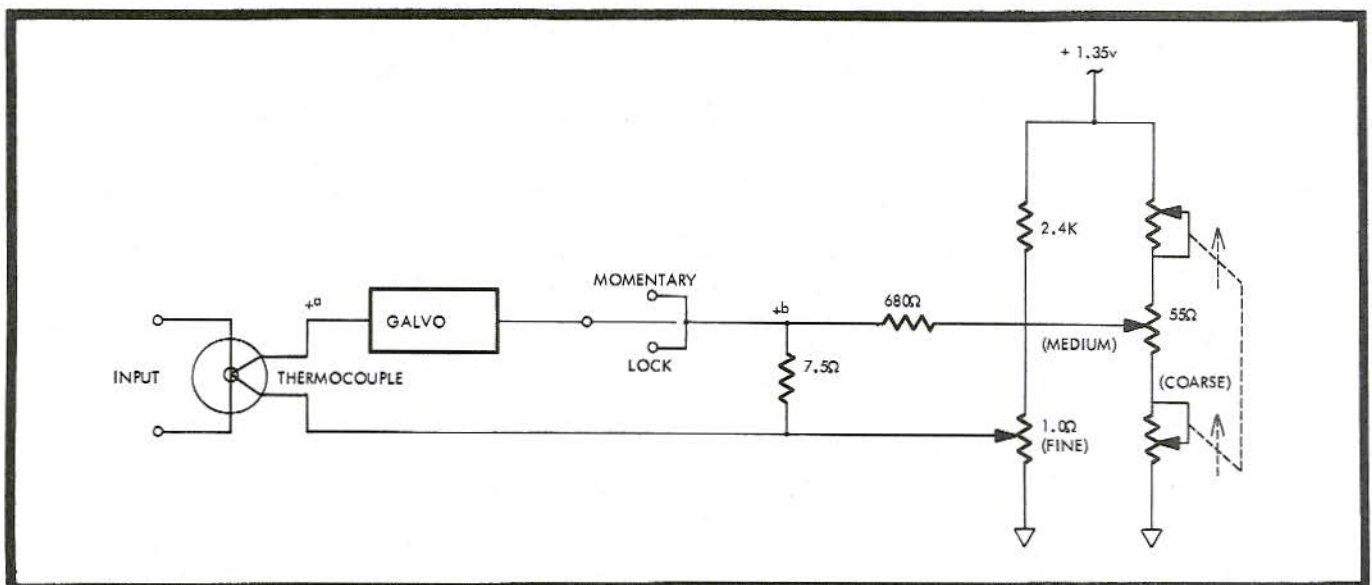

Figure 3-2. SIMPLIFIED BALANCE NETWORK

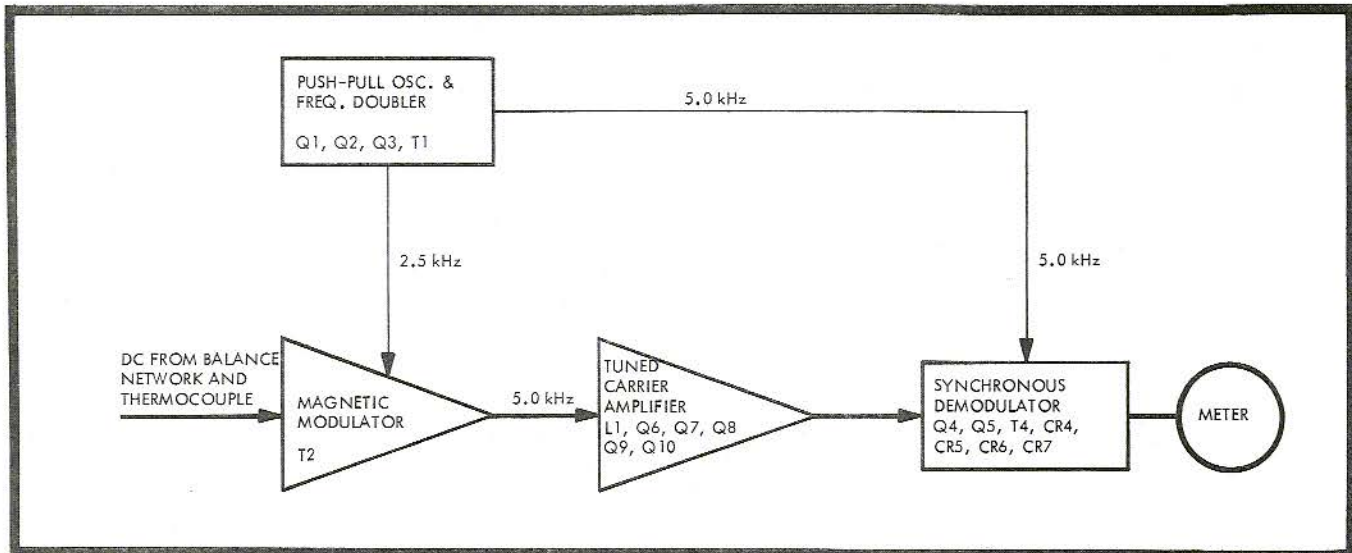

Figure 3-3. GALVANOMETER BLOCK DIAGRAM

3-25. **PUSH-PULL OSCILLATOR AND FREQUENCY DOUBLER.** Transistors Q1 and Q2 oscillate at a frequency of 2.5 kHz as determined by C2 and T1. Transformer T1 is adjustable and is used to set the operation frequency of the instrument. Transistor Q3 is used to control the amplitude of the oscillator output. The output of the oscillator, appearing across R10, peaks at a 5 kHz rate and is used to drive the Synchronous Demodulator. The 2.5 kHz signal from the oscillator is fed to the Magnetic Modulator from windings on transformer T1.

3-26. **MAGNETIC MODULATOR.** The Magnetic Modulator has been designed in such a manner as to produce a 5 kHz output. This 5 kHz output is proportional in level to the dc input of the Magnetic Modulator and its phase is dependent on the direction of the input current. R4 is the front panel zero adjust used to balance the modulator. The 5 kHz signal from the Magnetic Modulator is fed to transformer T3 which is the input for the Tuned Carrier Amplifier.

3-27. **TUNED CARRIER AMPLIFIER.** The input transformer to the Tuned Carrier Amplifier is tuned to resonance at 5 kHz during calibration. The signal is then fed to a two stage transistor amplifier. The SENSITIVITY switch controls the gain of these stages (Q6 and Q7). A variable inductance and series capacitor in the emitter circuit of Q8 serve to exclude all frequencies from the remaining stages except the desired 5 kHz. The variable inductance L1 is tuned for maximum output during calibration of the instrument. R36 is provided to adjust the gain of the Tuned Carrier Amplifier and is set during calibration of the instrument to provide the proper 5 kHz level to the Synchronous Demodulator.

3-28. **SYNCHRONOUS DEMODULATOR.** The primary components of the Synchronous Demodulator are transformer T4, transistors Q4 and Q5, and diodes CR4 thru CR7. The 5.0 kHz synchronizing signal to the demodulator is fed from the Push-Pull Oscillator and Frequency

Doubler thru C5. The 5.0 kHz signal to be demodulated is fed thru C19 from the Tuned Carrier Amplifier. Increasing the level of the signal from the Tuned Carrier Amplifier results in higher Synchronous Demodulator output appearing across the diode bridge and meter. It is characteristic of the Synchronous Demodulator that phase reversals in signal input, with no change in the synchronizing signal, cause reversals in the output of the demodulator.

3-29. BATTERY CHECK CIRCUITS

3-30. Battery check circuits have been provided to enable the operator to determine the adequacy of each of the battery supplies. Placing the POWER switch in the REFERENCE BATTERY CHECK position connects the PERCENT INPUT Meter in series with the Reference Battery and resistors R457 and R462. Resistor R458 has been provided to load the battery so that the Battery Check is accomplished under load. R462 has been calibrated so that the lower limit of the Battery Check band on the PERCENT INPUT Meter coincides with 1.0 volts from the Reference Battery BT105.

3-31. With the POWER switch in the GALV BATTERY CHECK position the PERCENT INPUT meter is connected in series with the galvanometer battery supply and resistors R461 and R455. Resistor R461 is adjusted so that the meter will indicate at the lower extreme of the Battery Check Band when 11.5 volts is supplied across the load resistor R456. Since the measurement is made under load it assures that adequate battery voltage is available for the Galvanometer and relay circuits.

3-32. With the POWER switch in the SEARCH BATTERY CHECK position the PERCENT INPUT meter is connected in series with the search battery supply and resistors R453 and R460. Resistor R460 is adjusted so that the meter will indicate at the lower extreme of the Battery Check Band when 11.5 volts is supplied across the load resistor R454.

3-33. RECHARGEABLE BATTERY PACK

3-34. The Model 540B Rechargeable Battery Pack supplies a rechargeable +12.5 volt dc source, a rechargeable center tapped +12.5 volt dc source, and a non-rechargeable +1.35 volt dc reference source for the Model 540B Thermal Transfer Standards galvanometer system. The rechargeable battery pack will allow the instrument to operate for more than 100 hours on a full charge. The single 1.35 volt battery will last for more than 2000 hours before replacement.

3-35. Refer to Detail I of the Model 540B Schematic Diagram in conjunction with the following discussion. Each of the rechargeable battery sections, BT1 and BT2, consist of ten nickel-cadmium batteries. The non-rechargeable battery, BT3, is a mercury battery used as the reference source for the Model 540B's galvanometer system. The pilot lamp, DS1, indicates when the power is applied to the unit for charging purposes. AC voltage is applied to the unit through plug P1 and coupled to the charging circuits through transformer T1. The full-wave rectifier bridges, CR1 through CR4 and CR5 through CR8, convert the ac voltages to dc voltages for charging their respective battery sections. Supply voltage for the galvanometer protection circuitry of the Model 540B is provided at pins 1 and 2. Supply voltage for the search amplifier and bias voltages for the diode circuit arrangements in the Model 540B and Model A54 are provided at pins 3, 4, and 6. Reference voltage source for the Model 540B galvanometer system is provided at pins 5 and 7.

3-36. A few precautions should be observed when using the Rechargeable Battery Pack. These precautions are listed as follows:

- a. Do not attempt accurate measurements while the batteries are charging.
- b. Full charge is obtained in 16 hours.

- c. Do not leave on charge for more than 72 hours.
- d. Replace the mercury reference battery as required.

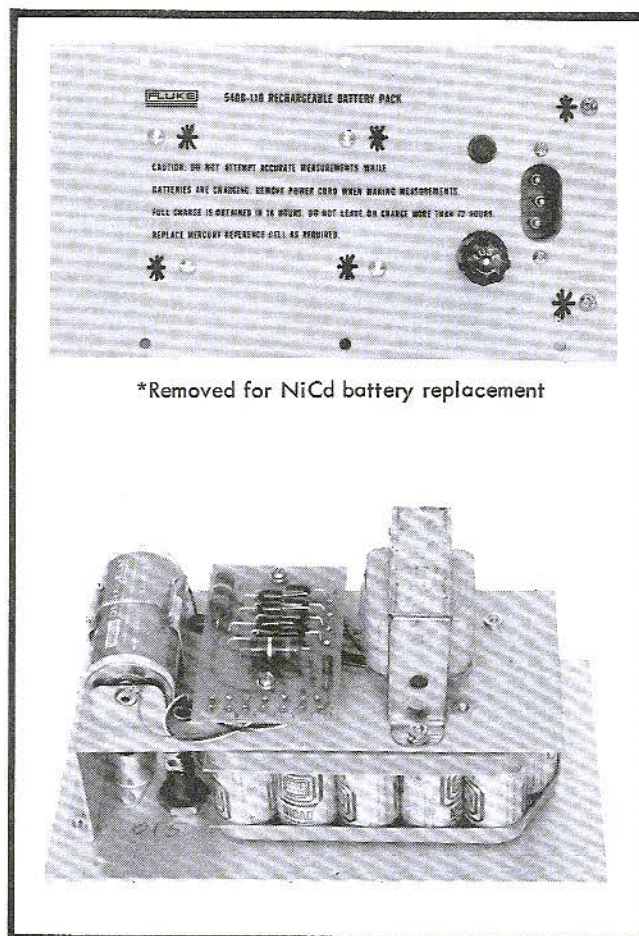

Figure 3-4. 540B RECHARGEABLE BATTERY PACK



SECTION IV

MAINTENANCE

4-1. GENERAL

4-2. The Model 540B Thermal Transfer Standard requires minimal routine maintenance, other than replacing the mercury batteries when they fail to meet the BATTERY CHECK requirements (Figure 2-4). Use caution when servicing the Model A54 Voltage Plug-In Unit, for any change of components or wiring may ne-

cessitate recalibration of the transfer ranges. Calibration procedures have been included for the battery check circuits, search circuit, protection circuit, and galvanometer. A check of the transfer mode calibration has been included. However, step-by-step transfer calibration has not been included because the test equipment required, with the necessary accuracy and stability, is not generally available.

EQUIPMENT	SPECIFICATIONS REQUIRED	USE	RECOMMENDED INSTRUMENT
Oscilloscope	Sweep range: 50 usec/cm to 1 msec/cm. Sensitivity: 50 mv/cm.	Calibration and Troubleshooting	Hewlett-Packard Model 120B Oscilloscope
Differential Voltmeter	Refer to Figure 2-3.	Calibration and Troubleshooting	Fluke Model 885A Differential Voltmeter
Power Supply	Refer to Figure 2-3.	Calibration and Troubleshooting	Fluke Model 332A Voltage Calibrator
Resistor	1 megohm $\pm 1\%$ 10 megohm $\pm 1\%$	Calibration and Troubleshooting	Any 1 meg $\pm 1\%$ resistor. Any 10 meg $\pm 1\%$ resistor.
Oscillator	10 Hz to 1 MHz $\pm 5\%$	Calibration and Troubleshooting	Hewlett-Packard Model 651B Test Oscillator
Frequency Counter	Must be able to measure 2.5 kHz with an accuracy of 0.1% ± 1 count.	Calibration	Hewlett-Packard Model 521 Electronic Counter
AC Voltmeter	Range: 400 uv to 150 mv. Accuracy: $\pm 3\%$	Troubleshooting	Fluke Model 910A True RMS Voltmeter
VTVM	Range: 1.5 to 15 volts dc full scale. Accuracy: $\pm 3\%$	Troubleshooting	RCA Voltomyst

Figure 4-1. CALIBRATION AND TEST EQUIPMENT

4-3. The calibration procedures outlined under Periodic Maintenance should be performed annually or oftener to provide the most satisfactory service from your Model 540B. The recommended test equipment is listed in Figure 4-1.

4-4. BATTERY INSTALLATION AND REMOVAL

4-5. Other than the battery condition checks (paragraph 2-11) and recharging, routine power pack maintenance is limited to battery replacement. Due to the advantage of being able to recharge the major battery sections, routine maintenance is further limited to replacement of the mercury reference battery, as required. Should it become necessary to replace any of the rechargeable batteries, the following instructions should be used.

- a. Remove the six screws indicated on the front panel of the battery pack in Figure 3-4.
- b. Slide the angle bracket assembly to one side.
- c. Carefully lift off one of the formed plastic battery holders to allow access to the batteries.
- d. Re-assemble after battery replacement.

CAUTION!

Non-rechargeable batteries should always be removed from the 540B if they fail the battery check, if the instrument is to be shipped, or if the instrument is to be stored for extended periods of time.

4-6. BATTERY CHECK CALIBRATION

4-7. Each battery section of the Model 540B (REFERENCE, GALV, and SEARCH) has a corresponding circuit that allows the PERCENT INPUT METER to indicate the condition of each battery section. Calibration of these circuits constitutes the setting of their adjustments, such that a low battery condition indication is established on the PERCENT INPUT meter scale, at the lower end of the green BAT OK band. These adjustments are set at the factory and should normally never have to be adjusted. Should a situation arise in which you feel that these circuits should be re-calibrated, use the following procedure for Model 540B's containing mercury battery packs. Should your Model 540B contain the Model 540B-110 Rechargeable Battery Pack, refer to paragraph 4-8.

- a. Model 540B POWER switch to OFF.
- b. Remove the battery pack from the rear of the Model 540B.
- c. Remove the battery hold down clamps and take out all of the batteries.
- d. Connect 1.0 volt (± 10 mv) dc between pins 7(-) and 5(+) on the battery pack printed circuit board.

4-2

- e. POWER switch to REFERENCE.
- f. Adjust R462 (see Figure 4-2) for a PERCENT INPUT meter indication at the lower limit of the BAT OK band.
- g. POWER switch to OFF. Remove connections.
- h. Connect 11.5 volts (± 100 mv) dc between pins 2(-) and 1(+).
- i. POWER switch to GALV.
- j. Adjust R461 (see Figure 4-2) for a PERCENT INPUT meter indication at the lower limit of the BAT OK band.
- k. POWER switch to OFF. Remove connections.
- l. Connect 11.5 volts (± 100 mv) dc between pins 3(-) and 4(+).
- m. POWER switch to SEARCH.
- n. Adjust R460 (see Figure 4-2) for a PERCENT INPUT meter indication at the lower limit of the BAT OK band.
- o. POWER switch to OFF. Remove connections.
- p. Install batteries and remount the battery pack in the Model 540B. (For the rechargeable battery pack, re-solder the corresponding wires to pins 1 and 4, install the 1.35 volt battery, and remount the battery pack.)

4-8. If your Model 540B contains the rechargeable battery pack, use the procedure of paragraph 4-7, substituting the following steps for step c of the calibration procedure.

- a. Remove the 1.35 volt battery.
- b. Unsolder the wire from the Model 540B wire harness at pin 1 of the rechargeable battery pack's printed circuit board. Treat this wire as pin 1 in the following calibration procedure.
- c. Unsolder the wire from the Model 540B wire harness at pin 4 of the rechargeable battery pack's printed circuit board. Treat this wire as pin 4 in the following calibration procedure.

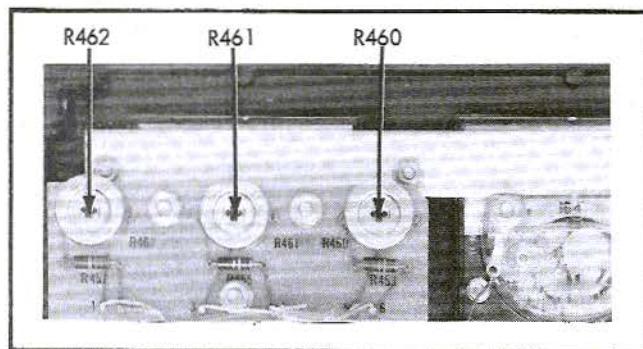

Figure 4-2. BATTERY CHECK CALIBRATION ADJUSTMENTS

4-9. PERIODIC MAINTENANCE

4-10. SEARCH METER CALIBRATION

4-11. Calibration of the search meter circuit requires sources of 10 and 0.5 volts dc, and rms ac at 500 Hz and 1 MHz, with $\pm 1.0\%$ accuracy. Remove the bottom cover from the Model 540B and proceed as follows:

- a. MODE switch to OFF.
- b. Connect a +10 volt dc source to the INPUT DC connectors on the A54 plug-in unit.
- c. POWER switch ON.
RANGE switch 10 volts.
MODE switch to DC SEARCH.
- d. Adjust R318 to obtain 0.5 volts (± 1 mv) dc on the differential voltmeter between the anode of CR312 and the chassis. Read and record the search meter reading ($100\% \pm 10\%$).
- e. Connect a +0.5 volt dc source to the INPUT DC connectors of the Model A54 plug-in unit.
- f. RANGE switch 0.5 volts.
- g. Read and record the search meter reading. Adjust R318 to obtain a search meter reading equal to the average value of the readings recorded in steps d and g.
- h. MODE switch OFF.
- i. Disconnect the 0.5 volt dc source and connect a 0.5 volt rms ac, 500 Hz source to the INPUT AC connector on the Model A54.
- j. MODE switch to AC SEARCH.
- k. Adjust R310 for a 100% reading on the PERCENT INPUT meter.
- l. MODE switch to OFF.
- m. Connect a 0.5 volt rms ac, 1 MHz signal to the INPUT AC of the Model A54.
- n. MODE switch to AC SEARCH.
- o. Adjust C305 for a 100% reading on the PERCENT INPUT meter. This completes the calibration of the search circuit in the Model 540B.

4-12. PROTECTION AMPLIFIER CALIBRATION

4-13. Remove the bottom cover from the Model 540B. Proceed as follows:

- a. MODE switch to OFF.
RANGE switch to 0.5 volts.
POWER switch to ON.
- b. Locate R314 and turn fully clockwise.
- c. Connect 0.73 ± 0.01 volts dc to the DC INPUT terminals.

- d. MODE switch to DC SEARCH.
- e. Rotate R314 counter-clockwise until the protection circuit operates, causing the PERCENT INPUT meter to deflect to the OVERLOAD area. The protection circuit should operate within 0.70 to 0.75 volts dc at the DC INPUT terminals.
- f. Remove the dc input voltage.
- g. Reset the protection circuit by setting the MODE switch to OFF and then back to DC SEARCH.
- h. Apply a -0.70 volts dc to the DC INPUT terminals. Increase the input voltage in 0.01 volt dc steps until the protection circuit operates. The protection circuit should operate between 0.70 and 0.75 volts dc.
- i. Adjust R314 until the protection circuit operates in both polarities of the dc input within 0.70 to 0.75 volts dc.
- j. Remove the dc input voltage.
- k. MODE switch to OFF.
- l. Connect the output of an oscillator, set to 1 kHz at zero volts, to the AC INPUT connector. Monitor the oscillator output with an ac voltmeter.
- m. MODE switch to AC SEARCH.
- n. While observing the ac voltmeter, increase the oscillator output amplitude until the protection circuit operates. Record the output voltage of the oscillator, observed on the ac voltmeter, at the time of protection circuit operation.
- o. Reduce the oscillator amplitude to zero volts. Reset the protection circuit by setting the MODE switch to OFF and then back to AC SEARCH.
- p. Repeat steps k through o at 10 Hz, 500 kHz, and 1 MHz. The protection circuit should operate between 0.60 and 0.75 volts rms ac at all frequencies.
- q. Set the MODE switch to OFF and remove all test equipment.
- r. Place the bottom cover on the Model 540B.

4-14. GALVANOMETER CALIBRATION

4-15. OSCILLATOR AMPLITUDE AND FREQUENCY. Set the POWER switch in the OFF position. Remove the top cover on the Model 540B. Remove the screws securing the battery pack to the Model 540B. Carefully slide the battery pack out of the Model 540B and place the pack in such a position as not to cause undue stress upon the connecting wire harness. Proceed as follows:

- a. Connect an oscilloscope vertical input to the lead of R5 nearest Q1. Connect the oscilloscope ground to the negative end of C1.

- b. GALV switch OPEN.
SENSITIVITY switch LOW.
POWER switch ON.
- c. Adjust R6 for a 1.2 \pm 0.1 volt peak-to-peak waveform displayed on the oscilloscope.
- d. Remove oscilloscope connections.
- e. Connect an electronic counter between the lead of R5 nearest Q1 and the negative end of C1.
- f. Adjust the core of T1 for a 2500 \pm 5 Hz indication on the electronic counter. (The core of T1 is adjustable from the land pattern side of the circuit board. Access to the adjustment is through the opening left from removing the battery pack.)
- g. Remove all test connections and set the POWER switch to OFF.
- h. Re-install the battery pack and top cover on the Model 540B.

4-16. **TUNED CARRIER AMPLIFIER ALIGNMENT.** Remove the side cover on the galvanometer side of the Model 540B. Refer to Figure 4-4 for adjustment and connection locations. Connect equipment as shown in Figure 4-3 and use a 1 megohm \pm 1% resistor for R_x . Proceed as follows:

- a. Connect the oscilloscope vertical input to the junction of R34 and R35 (junction E). Connect oscilloscope ground to T2 mounting screw.
- b. Set the oscilloscope controls for 100 millivolts per centimeter of vertical deflection and 50 microseconds per centimeter of horizontal deflection.
- c. GALV switch OPEN.
SENSITIVITY switch LOW,
POWER switch ON.
- d. Adjust power supply for 3 volts \pm 100 mv (3 ua input).
- e. With a non-metallic screwdriver, adjust the core of T3 (adjustment H) for a maximum 5 kHz signal level, as seen on the oscilloscope.
- f. With a non-metallic screwdriver, adjust the core of L1 (adjustment J) for a maximum deflection to the right on the GALVANOMETER meter (approximately 20 \pm 5% of full scale).
- g. Repeat steps (e) and (f) for a maximum signal indication on both the GALVANOMETER meter and the oscilloscope.

4-17. **TUNED CARRIER AMPLIFIER GAIN.** Check and readjust, if necessary, the mechanical zero of the GALVANOMETER meter. Connect the equipment as shown in Figure 4-3 and use a 10 megohm \pm 1% resistor for R_x .

- a. GALV switch OPEN.
SENSITIVITY switch HIGH.
POWER switch ON.

4-4

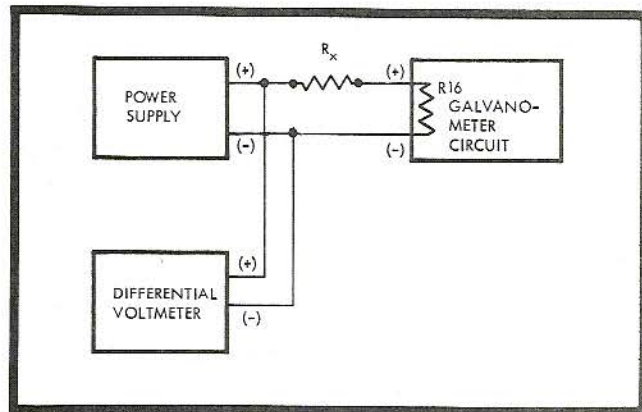

Figure 4-3. ELECTRONIC GALVANOMETER CALIBRATION

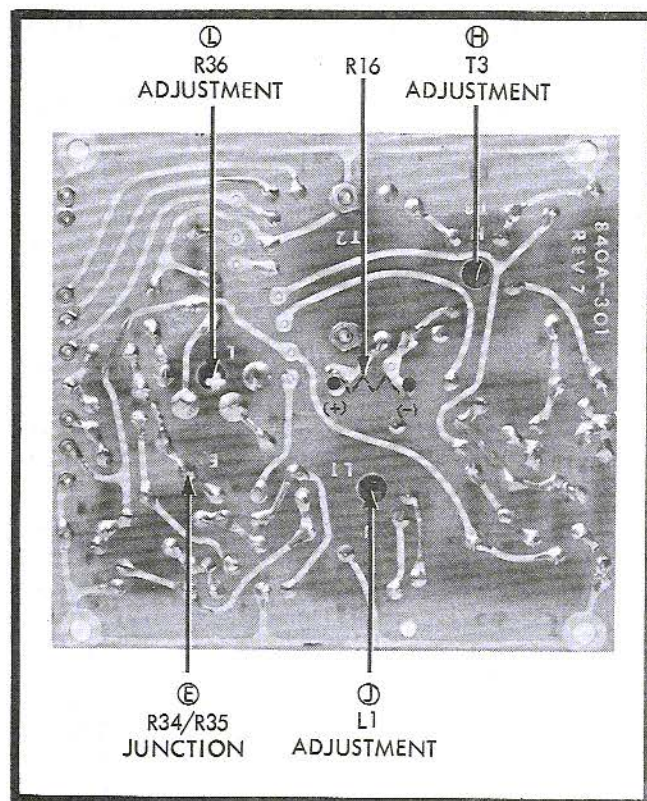

Figure 4-4. TUNED CARRIER AMPLIFIER ADJUSTMENTS

- b. Adjust the power supply output for 0.3 volt \pm 10 millivolts (30 na input).
- c. Adjust R36 (adjustment L) for 8 minor divisions deflection to the right on the GALVANOMETER meter.
- d. Reverse the polarity of the power supply and check the deflection of the GALVANOMETER meter. Should the deflection in steps c and d be unequal, adjust R36 for the best average deflection in both polarities (not to exceed 8 \pm 1.0 minor divisions in either polarity).

4-18. **SENSITIVITY TEST CALIBRATION.** Calibration of the **SENSITIVITY TEST** circuit requires a dc voltage source with an accuracy of $\pm 0.003\%$. Refer to Figure 5-2 for adjustment locations. Remove the bottom cover of the Model 540B and proceed as follows:

- a. GALV switch OPEN
RANGE switch .5
MODE switch DC SEARCH
SENSITIVITY switch LOW
- b. Connect 0.50055 volts dc to the DC INPUT terminals.
- c. Set all REFERENCE ADJUST controls to the center of their ranges.
- d. MODE switch DC TRANSFER
GALV switch LOCK
- e. Adjust COARSE and MEDIUM controls for zero reading on the GALVANOMETER.
- f. GALV switch OPEN
SENSITIVITY switch HIGH
- g. Adjust GALV ZERO for zero reading on the GALVANOMETER.
- h. GALV switch to LOCK.
- i. Adjust MEDIUM and FINE controls for zero reading on the GALVANOMETER.
- j. Adjust external voltage source for 0.50005 volts dc at the DC INPUT terminals.
- k. SENSITIVITY TEST switch to 0.1%.
- l. Adjust R402 for zero ± 5 minor divisions GALVANOMETER deflection.
- m. Set SENSITIVITY TEST switch to OPR, and adjust external voltage source for 0.50055 volts dc.
- n. GALV switch to OPEN.
- o. Adjust GALV ZERO for zero reading on the GALVANOMETER.
- p. GALV switch to LOCK.
- q. Adjust MEDIUM and FINE controls for zero reading on the GALVANOMETER.
- r. Adjust external voltage source for 0.50050 volts dc at the DC INPUT terminals.
- s. SENSITIVITY TEST switch to 0.01%.
- t. Adjust R401 for zero ± 0.5 minor divisions GALVANOMETER deflection.
- u. SENSITIVITY TEST switch OPR
GALV switch OPEN
- v. Disconnect test equipment and replace bottom cover on Model 540B.

4-19. PRELIMINARY TRANSFER CALIBRATION CHECK

4-20. GENERAL

4-21. Any method of checking the Model 540B transfer calibration consists of checking it against a standard of known accuracy. Laboratory transfer equipment, whose accuracy equals or exceeds the specifications of the Model 540B, with a current test report from NBS traceable standards may be used. A Model 540B with a recently issued test report may be used to check another Model 540B over its entire range. In addition to a known standard of comparison, it will also be necessary to have a complete set of equipment as outlined in Figure 2-3.

4-22. The Model 540B under test must pass all of the isolation tests (3) and the reversal tests, before a valid check may be made of transfer calibration. It is necessary to note that should the Model 540B fail to pass the calibration check of the .5 volt range, it is reasonable to assume that all of the ranges are out of calibration. The basic compensation is made in the .5 volt range and all ranges are dependent upon this compensation. Should the .5 volt range be within the limits of calibration it is reasonable to proceed with the calibration checks of the other ranges. No other range will so effect the calibration of any other range, as each range is compensated dependent on the .5 volt compensation and its own compensating elements.

4-23. If a range is found to be out of specified limits and it is not feasible to send the instrument back to the factory for recalibration, it may be checked at each frequency and voltage to be used and a correction chart made to calculate the deviations. Should the reversal error or heater to couple isolation tests fail to meet specifications it will be necessary to replace the thermocouple and the instrument should be recalibrated.

4-24. REVERSAL ERROR

4-25. Check in accordance with Section 2-15.

4-26. HEATER TO COUPLE ISOLATION

4-27. The purpose of this test is to insure the adequate isolation between the heater and the couple element of the thermocouple. Proceed as follows:

- a. POWER switch OFF.
MODE switch DC TRANSFER.
GALV switch OPEN.
HIGH FREQ CONVERTER plug removed.
- b. Measure the resistance between pin 1 or pin 2 of the HIGH FREQ CONVERTER jack and the negative DC INPUT (lower) binding post. This resistance must be 10 megohms or higher. Restore the HIGH FREQ CONVERTER plug and turn the MODE switch to OFF.

4-28. GALVANOMETER GROUND ISOLATION

4-29. The purpose of this test is to verify the isolation of the galvanometer circuit from chassis ground. Pro-

ceed as follows:

- a. Remove Q304 from the 540B-401 circuit board (Search and Protection Amplifier PCB).
- b. POWER switch to OFF.
- c. With an ohmmeter (Simpson 260 or equivalent) check the resistance between the mounting screw of T2 on printed circuit board 840A-401 and 540B chassis ground. Place the probe on positive connection of the ohmmeter to ground.
- d. The resistance must be 40k or higher.
- e. Replace Q304.

4-30. GALVANOMETER INPUT ISOLATION

4-31. The purpose of this test is to assure the isolation of the galvanometer input circuit from galvanometer ground. It is necessary to use an instrument capable of measuring 100 megohms. The following procedure is intended for use with a FLUKE differential voltmeter, such as the Model 885 suggested in Figure 4-1. Remove the HIGH FREQ CONVERTER plug and proceed as follows:

- a. POWER switch to OFF.
- b. SENSITIVITY switch to LOW.
- c. GALV switch to OPEN.
- d. Connect the 885 differential voltmeter to either end of R16 and one of the T2 mounting screws (see Figure 4-4).
- e. Dial the voltmeter to 10 volts.
- f. Place the NULL switch in the .001 position.
- g. The Model 885 meter deflection must be less than full scale.
- h. Disconnect the Model 885 and replace the HIGH FREQ CONVERTER plug.

4-32. PROTECTION DISABLE CHECK (Model A54-2)

4-33. During dc or low frequency (up to 10 kHz) ac transfer measurements, the PROTECTION DISABLE switch can be actuated to verify correct operation. When actuated, a resulting GALVANOMETER meter deflection greater than one minor division indicates incorrect operation. The diode protection bridge should be investigated for component failure should this occur. At frequencies higher than 10 kHz a meter deflection greater than one minor division will be noted. This is normal for the instrument.

4-34. TRANSFER CALIBRATION CHECK

4-35. The following procedure is intended to check, rather than calibrate, the transfer ranges of the Model

4-6

540B. It is essential that the person checking the calibration be thoroughly familiar with the use of the Model 540B and the system being used as a calibration standard before attempting these procedures. It is suggested that every measurement in this procedure be accomplished at least four times or until repeatability is attained. The dc reference voltage should be checked immediately after any measurement to assure its stability. Should it be impossible to attain a good degree of repeatability in any test, the results of that test are not reliable and should be disregarded until repeatability is attained.

- a. Connect the equipment as shown in Figure 4-5 observing the precautions mentioned in Section 2-9.

Note!

When connecting the transfer standards as shown in Figure 4-5, it is mandatory that the leads be kept as short as possible. It is also necessary that all ac leads have losses equal to the losses in the comparable dc leads. Ten milliohms of lead loss difference represents a .01% error in the transfer readings on the 0.5 volt range.

- b. Prepare a test record similar to the one shown in Figure 4-5.
- c. Take reversal error readings on both transfer standards as explained in Section 2-15 and record the results on the test record.

Note!

In order to conform with National Bureau of Standards notations, all deflections of the Galvanometer to the left (less input) are assigned + and all deflection to the right (more input) are assigned - notation.

- d. The reversal error measured should be divided by 2 and entered as the Corrected Zero as shown in the example. This corrected zero will be the zero setting for all dc inputs for the remainder of the tests.
- e. In the column TEST REPORT CORRECTIONS enter the correction figures given in the Test Report of the instrument being used as the standard instrument.
- f. Apply 0.5 volts of dc to the coaxial "T" connector and apply 0.5 volts rms ac of the desired check frequency to the adjacent coaxial "T" connector.
- g. With both Transfer Standards in the DC TRANSFER MODE of operation proceed to null the galvanometers using the lindecks or other reference adjust controls on succeeding more sensitive positions of the galvanometers until both galvanometers are nulled at the Corrected Zero points as computed on the test record.
- h. Deflection sensitivity should be computed as per Section 2-13 so that all remaining readings may be properly recorded on the test record.

REVERSAL ERROR CORRECTION	540B UNDER TEST	STANDARD INSTRUMENT	
DC NORMAL	ZERO	ZERO	
DC REVERSED	+4 SD	-6 SD	
CORRECTED ZERO (NORMAL)	-2 SD	+3 SD	
TRANSFER CALIBRATION CHECK			
	540B Under Test	Test Report Corrections	Corrected Error
.01% Deflection Percent/Division	7 SD .001%	* 8 SD .001%	
50 Hz Deviation % Deviation	+3 SD +.004%	+.002%	+.006%
50 kHz Deviation % Deviation	-16 SD -.023%	+.01%	-.013%
1 MHz Deviation % Deviation	+28 SD +.04%	-.02%	+.02%
* Deviation for standard transfer instrument.			

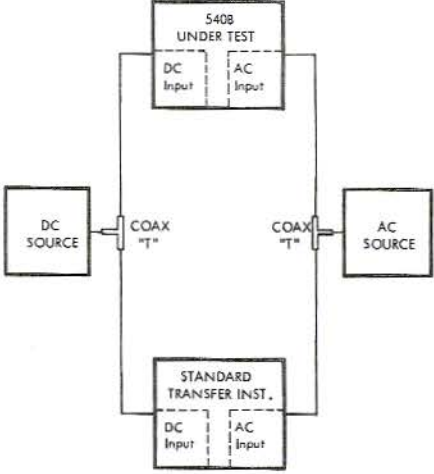

Figure 4-5. TRANSFER CALIBRATION CHECK

- i. Switch both standards to the AC TRANSFER MODE and adjust the ac source level for a true zero reading on the standard system galvanometer. Do not adjust the reference controls or lindeck of either system while in the AC MODES.
- j. Operate the GALV switch to LOCK and read the deflection of the galvanometer on the 540B being checked. (Left deflection is + and right deflection is -).
- k. Switch both transfer systems back to DC TRANSFER MODE to determine if the dc level has drifted. If both systems do not return to the settings made in step g, it will be necessary to repeat the transfer process starting with step g. Steps g thru k will have to be repeated until a finite degree of repeatability is attained. This is usually considered to be three near identical readings in a total of four attempts. After obtaining a series of near identical readings enter the average on the test record and compute the percent of deviation from zero. Add the figure just computed and the Test Report correction for the standard instrument. The sum will equal the corrected error and may be entered in the space provided in the test record.
- l. Steps f thru k will have to be repeated for every frequency to be checked. Should the instrument fail calibration check in the 0.5 volt range, it is reasonable to assume that all ranges will be in error, as pointed out in Section 4-21. In this case it will be necessary to return the instrument to the factory or some other facility capable of recalibrating the 540B.
- m. Steps a thru l will have to be repeated for every range or voltage to be checked.

4-36. TROUBLESHOOTING

4-37. GENERAL

4-38. The Model 540B must have a complete set of batteries that are within the limits given in the battery check range. Low voltage from the batteries will result in a variety of trouble indications, including complete failure of the instrument. If there is any doubt as to the adequacy of the batteries to supply sufficient voltage they should be changed before any other corrective action is taken.

4-39. THERMOCOUPLE REPLACEMENT

4-40. Should the thermocouple become damaged, replacements are available from the factory. However, to realize the full accuracy capability of the instrument, the Model 540B should be returned to the factory for recalibration.

CAUTION!

If for any reason any of the components or wiring in that portion of the circuit between the input terminals and the thermocouple, are changed or moved it will be necessary to recalibrate the Model A54. Any changes in this portion of the circuit can cause large calibration changes in the higher frequency transfers.

SYMPTOM	POSSIBLE CAUSE	REMEDY
No PERCENT INPUT meter reading.	Low galvo battery. K801 not making contact.	Replace batteries. Clean the contacts.
Erratic transfer readings or unstable galvo.	Poor test lead connections. Unstable dc or ac sources. Low Galvo battery. K801 not making good contact. Dirty MODE switch contacts.	Check all connecting cables and wiring. Check source stability. Replace batteries. Clean the contacts. Clean the switch contacts.
Galvanometer sensitivity low.	Galvanometer circuit out of alignment. Input too low for the range selected.	Realign the galvanometer. Using the PERCENT INPUT meter in the SEARCH MODE, reduce the range setting until a reading nearer 100% is obtained.
GALV ZERO inoperative.	Galvanometer circuit out of alignment. Protection circuit operated.	Realign the galvanometer. Recheck the PERCENT INPUT meter and if an overload has occurred, determine the reason for the over load, correct the problem and reset the protection circuit.
Fails Input Isolation check. (Paragraph 4-30)	Input leads to T2 touching the case. Defective T2.	Check the leads to T2 and move them away from the case. Replace T2.
Protection circuit fails to calibrate.	Defective diode(s). Defective transistor(s).	Check diodes CR303 to 306, CR310 to 303, CR307 and CR314, and Q303 and Q304.

Figure 4-6. TROUBLESHOOTING

SECTION V

LIST OF REPLACEABLE PARTS

5-1. INTRODUCTION

5-2. This section contains information necessary to describe all normally replaceable parts. Separate assembly lists are used to describe the parts on the final assembly and various assemblies and subassemblies. Each list has a corresponding illustration on which the parts for that list are identified. Parts are called out on both lists and illustrations by reference designations from the schematic diagram. Those parts (mechanical) which have no reference designation are shown on the illustrations by Fluke stock number.

5-3. Each list provides the following information on each part:

- a. The REF DESIG. column indicates the reference designation used on the schematic diagram.
- b. The DESCRIPTION column describes the part in words, along with any applicable values, tolerances, etc. Indentation is used to show assembly, subassembly, and parts relationship. See abbreviations and symbols on next page.
- c. Entries in the FLUKE STOCK NO. column indicate the number by which Fluke stocks the part. This number should be used when ordering parts from the Fluke factory or your Fluke representative.
- d. Entries in the MFR. column indicate a typical manufacture of the part by the manufacturer's code number. Appendix A lists the manufacturers and their code numbers.
- e. Entries in the MFR. PART NO. column are part numbers assigned by the manufacturer indicated in the MFR column.
- f. The number in the TOT. QTY. column indicates the total quantity of the part used in the instrument. "REF" indicates that the total quantity of the part has been previously given. The total quantity of each part is listed the first time the part appears. All other listings of the same part refer back to the reference designation of the first appearance of the part for the total quantity.
- g. The number in the REC. QTY. column indicates the recommended spares quantity necessary to support approximately one to five instruments for a period of two years. The basis used to select the recommended spares quantity is that a small group of parts will be required to correct a majority of the problems that occur. Since there is a chance that any part may fail, a stock of at least one of every part used in addition to the recommended parts will be needed for complete maintenance during one year of isolated service.
- h. The USE CODE column identifies certain parts which have been added, deleted, or modified during production of the instrument. Each part for which a use code has been assigned may be identified with a particular instrument serial number by consulting the Use Code Effectivity List at the end of this section. These changes are normally made when improved components become available or when the latest circuit improvements are developed by our engineering department. The serial number listed indicates the instruments in which that particular part was used. The symbol "~" is used to indicate an approximate use code. If a different part should be used for replacement, it is listed by Fluke stock number in the description column.

5-4 HOW TO OBTAIN PARTS

5-5. Standard components have been used wherever possible. Standard components may be ordered directly from the manufacturer by using the manufacturer's part number, or parts may be ordered from the John Fluke Mfg. Co. factory or authorized representative by using the Fluke part number. In the event the part you order has been replaced by a new or improved part, the replacement will be accompanied by an explanatory note and installation instructions, if necessary.

5-6. You can insure prompt and efficient handling of your order to the John Fluke Mfg. Co. if you include the following information:

a. Quantity.

b. FLUKE Stock Number.

c. Description.

d. Reference Designation.

e. Instrument model and serial number.

Example; 2 each, 4805-177105, Transistors, 2N3565, Q107-108 for 845AR, s/n 168.

If you must order structural parts not listed in the parts list, describe the part as completely as possible. A sketch of the part showing its location to other parts of the instrument is usually most helpful.

5-7. LIST OF ABBREVIATIONS

ac	alternating current	mw	milliwatt
Al	Aluminum	na	nanoampere
amp	ampere	nsec	nanosecond
assy	assembly	nv	nanovolt
cap	capacitor	Ω	ohm
car flm	carbon film	ppm	parts per million
C	centigrade	piv	peak inverse voltage
cer	ceramic	p-p	peak to peak
comp	composition	pf	picofarad
conn	connector	plstc	plastic
db	decibel	p	pole
dc	direct current	pos	position
dpdt	double-pole, double-throw	P/C	printed circuit
dpst	double-pole, single-throw	rf	radio frequency
elect	electrolytic	rfi	radio frequency interference
F	fahrenheit	res	resistor
Ge	germanium	rms	root mean square
gmv	guaranteed minimum value	rtry	rotary
h	henry	sec	second
Hz	hertz	sect	section
hf	high frequency	S/N	serial number
IC	integrated circuit	Si	silicon
if	intermediate frequency	scr	silcon controlled rectifier
k	kilohm	spdt	single-pole, double-throw
kHz	kilohertz	spst	single-pole, single-throw
kv	kilovolt	sw	switch
lf	low frequency	Ta	tantalum
MHz	megahertz	tstr	transistor
M	megohm	tvm	transistor voltmeter
met flm	metal film	uhf	ultrahigh frequency
ua	microampere	vtvm	vacuum tube voltmeter
uf	microfarad	var	variable
uh	microhenry	vhf	very high frequency
usec	microsecond	vlf	very low frequency
uv	microvolt	v	volt
ma	milliampere	va	voltampere
mh	millihenry	vac	volts, alternating current
m	milliohms	vdc	volts, direct current
msec	millisecond	w	watt
mv	millivolt	ww	wire wound

REF DESIG.	DESCRIPTION	FLUKE STOCK NO.	MFR.	MFR. PART NO.	TOT. QTY.	REC. QTY.	USE CODE
	FINAL ASSEMBLY-Figure 5-1	3158-178236	89536	3158-178236	1		
	Front Panel Assembly (See Figure 5-2)	3158-178194	89536	3158-178194	1		
	Oscillator/Synchronous Demodulator Assembly (See Figure 5-3)	1702-151597 (840A-402)	89536	1702-151597	1		
	Magnetic Modulator/Carrier Amplifier Assembly (See Figure 5-4)	1702-165803 (840A-401)	89536	1702-165803	1		
	Search and Protection Amplifier Assembly (See Figure 5-5)	1702-178186 (540B-401)	89536	1702-178186	1		
	A54-1 Assembly	3158-178152	89536	3158-178152	1		
	A54-2 Assembly (See Figure 5-6)	3158-209163	89536	3158-209163	1		
BT101 to BT104	* Battery, mercury, 6.75v (not illustrated)	4001-161778	72665	TR235R	6		AA
BT105	Battery, mercury, 1.35v (not illustrated)	4001-103226	72665	RM42R	1		AA
BT106, BT107	* Battery, mercury, 6.75v (not illustrated)	4001-161778	72665	TR235R	REF		AA
J101	Plug, female, 24 terminal	2105-178012	02660	2619024	1		
K301	Relay, DPDT	4504-176347	86689	62-760	1		
R459	Res, comp, 12K $\pm 10\%$, 1/2W	4704-108977	01121	EB1231	4		
	Feet, rubber (not illustrated)	2819-103309	77969	9102W	8		
	Handle	2404-101857	12136	919-415-173	1		
	Side Casting	3156-177857	89536	3156-177857	2		

* Non-rechargeable batteries deleted and rechargeable battery pack (page 5-22) made standard at S/N 929 and on.

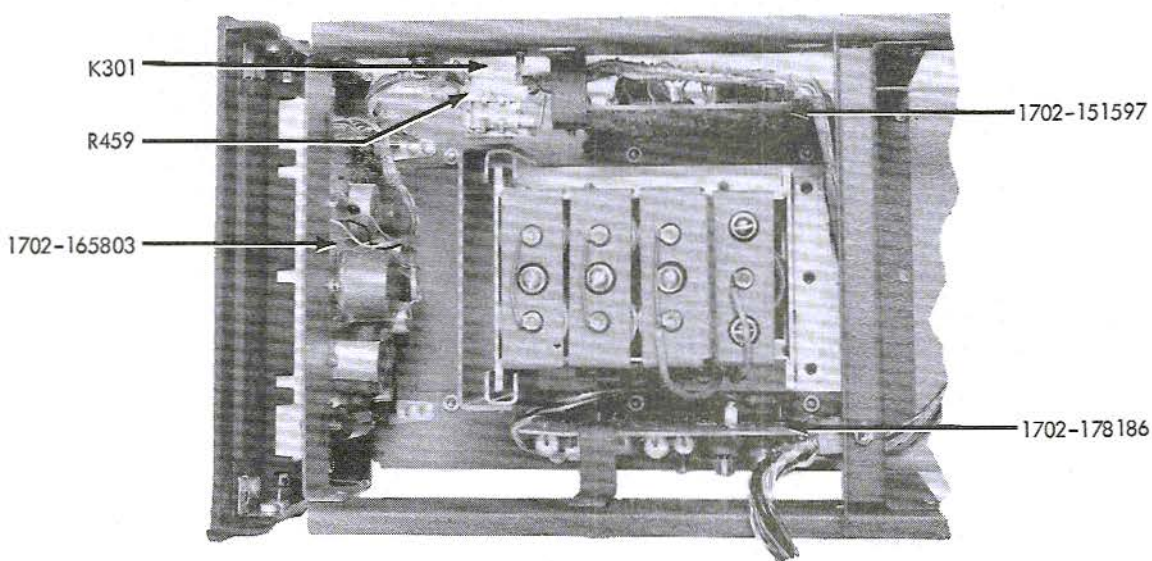

Figure 5-1. FINAL ASSEMBLY (Sheet 1 of 2)

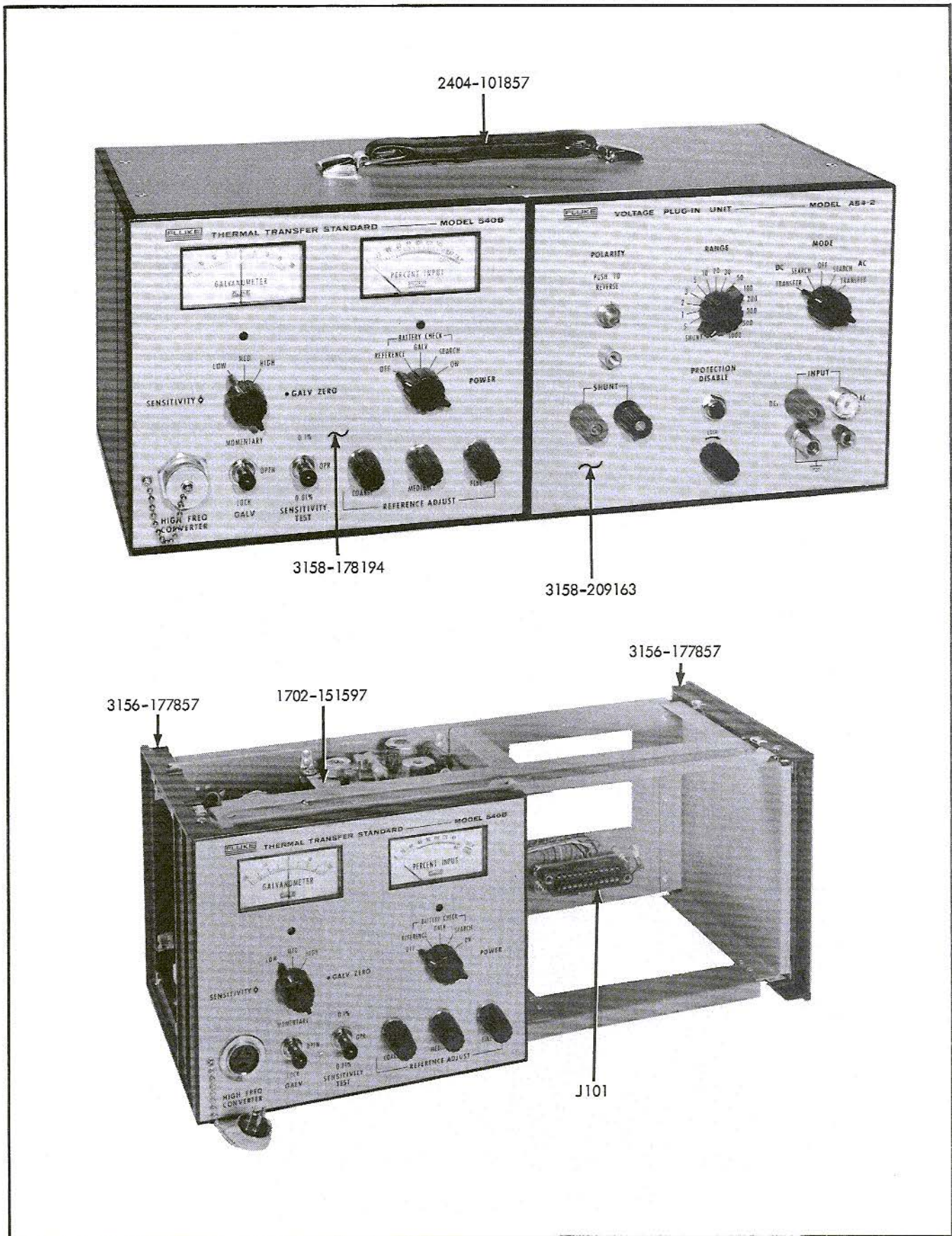

Figure 5-1. FINAL ASSEMBLY (Sheet 2 of 2)

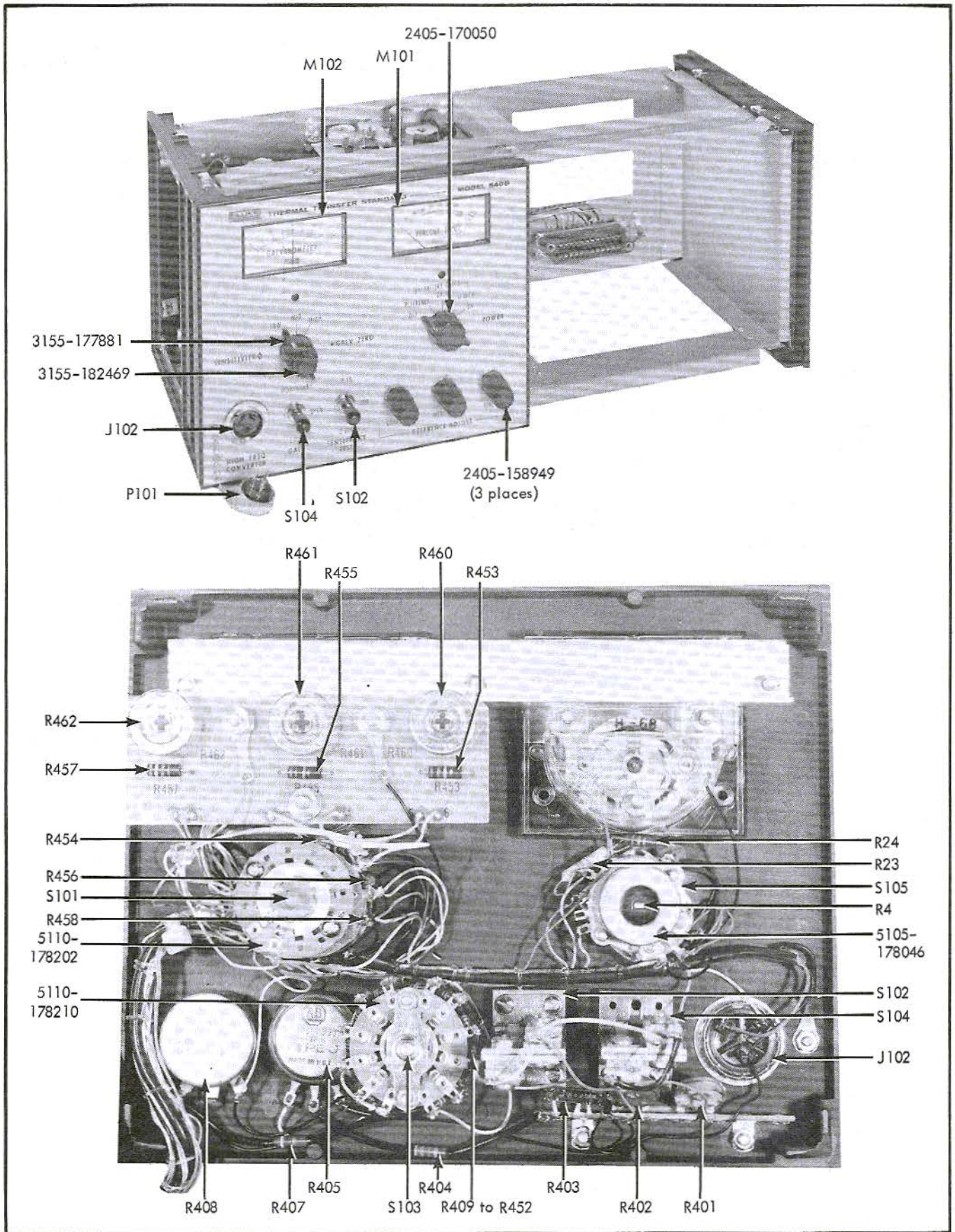

Figure 5-2. FRONT PANEL ASSEMBLY

REF DESIG.	DESCRIPTION	FLUKE STOCK NO.	MFR.	MFR. PART NO.	TOT. QTY.	REC. QTY.	USE CODE
	FRONT PANEL ASSEMBLY Figure 5-2	3158-178194	89536	3158-178194	REF		
J102	Connector, 3 pin	2109-103101	02660	91-PC3F	1		
M101	Meter, (Percent Input)	2901-161828	89536	2901-161828	1		
M102	Meter, (Galvanometer)	2901-161836	89536	2901-161836	1		
P101	Plug, (HFTC)	2109-122267	89536	2101-103101	1		
R401	Res, comp, 51K $\pm 10\%$, 1/2W	4704-165753	01121	EB5131	1		E
	Res, comp, 47K $\pm 10\%$, 1/2W	4704-108480	01121	EB4731	2		F
	Res, comp, 39K $\pm 5\%$, 1/2W	4704-186049	01121	EB3935	1		G
	Res, var, comp, 50K $\pm 30\%$, 1/4W	4701-183095	71450	X-201	1		U
R402	Res, comp, 5.1K $\pm 10\%$, 1/2W	4704-109108	01121	EB5121	1		E
	Res, comp, 4.7K $\pm 10\%$, 1/2W	4704-108381	01121	EB4721	3		F
	Res, comp, 3.9K $\pm 5\%$, 1/2W	4704-180596	01121	EB3945	1		G
	Res, var, comp, 5K $\pm 30\%$, 1/4W	4701-183103	71450	X-201	1		U
R403	Res, WW, 7.5 Ω $\pm 5\%$, 1/2W	4707-131797	89536	4707-131797	1		
R404	Res, comp, 680 Ω $\pm 5\%$, 1/2W	4704-178392	01121	EB6815	1		
R405	Res, WW, var, 55 Ω $\pm 10\%$, 1/4W	4701-176677	01121	JA1NO56P-550UA	1		
R407	Res, comp, 2.4K $\pm 5\%$, 1/2W	4704-108902	01121	EB2425	1	1	
R408	Res, WW, var 1 Ω $\pm 10\%$, 2W	4701-113001	12697	CM29343	1		
	Power Switch Assembly	5110-178202	89536	5110-178202	1	1	
R454	Res, comp, 2.2K $\pm 10\%$, 1/2W	4704-108605	01121	EB2221	1		
R456	Res, comp, 390 Ω $\pm 10\%$, 1/2W	4704-108365	01121	EB3911	1		
R458	Res, comp, 820 Ω $\pm 10\%$, 1/2W	4704-108423	01121	EB8211	1		
S101	Switch, rotary, 5 pos	5104-178368	89536	5104-178368	1	1	
	Galvo Sensitivity Switch and Zero Pot Assembly	5105-178046	89536	5105-178046	1		
R4	Res, var, 1.0M (Part of the 5105-178046 assembly)				-		
R23	Res, met film, 105 Ω $\pm 1\%$, 1/2W	4705-151100	75042	Type-CEC-TO	1		
R24	Res, comp, 5.1 Ω $\pm 5\%$, 1/2W	4704-177147	01121	EB51G5	1		
S105	Switch, rotary, 3 position (Part of the 5105-178046 assembly)				-		
	Lindeck Switch Assembly	5110-178210	89536	5110-178210	1	1	
R409 to R452	Res, comp, 43 Ω $\pm 5\%$, 1/4W	4704-177162	01121	CB4305	44		

REF DESIG.	DESCRIPTION	FLUKE STOCK NO.	MFR.	MFR. PART NO.	TOT. QTY.	REC. QTY.	USE CODE
S103	Switch, rotary (COARSE ADJ)	5105-178350	89536	5105-178350	1	1	
R453, R455	Res, comp, 15K $\pm 10\%$, 1/2W	4704-108530	01121	EB1531	2		J
	Res, comp, 12K $\pm 10\%$, 1/2W	4704-108977	01121	EB1231	REF		
R457	Res, comp 680 Ω $\pm 10\%$, 1/2W	4704-108712	01121	EB6811	2		J
	Res, comp, 270 Ω $\pm 10\%$, 1/2W	4704-108241	01121	EB2711	1		K
	Res, comp, 180 Ω $\pm 10\%$, 1/2W	4704-108571	01121	EB1811	2		L
R460, R461	Res, var, WW 6K $\pm 5\%$, 1-1/4W	4702-113029	71450	Type 110	2		
R462	Res, var, WW 300 Ω $\pm 10\%$, 1-1/4W	4702-112870	71450	Type 110	1		
S102	Switch, lever (SENSITIVITY TEST)	5106-176594	82389	6S-2457	1	1	
S104	Switch, lever (LOCK GALV)	5106-176602	82389	6S-2458	1		
	Knob (POWER)	2405-170050	89536	2405-170050	1		
	Knob (SENSITIVITY)	3155-177881	89536	3155-177881	1		
	Knob (GALV ZERO)	3155-182469	89536	3155-182469	1		
	Knob (REFERENCE ADJUST)	2405-158949	89536	2405-158949	3		

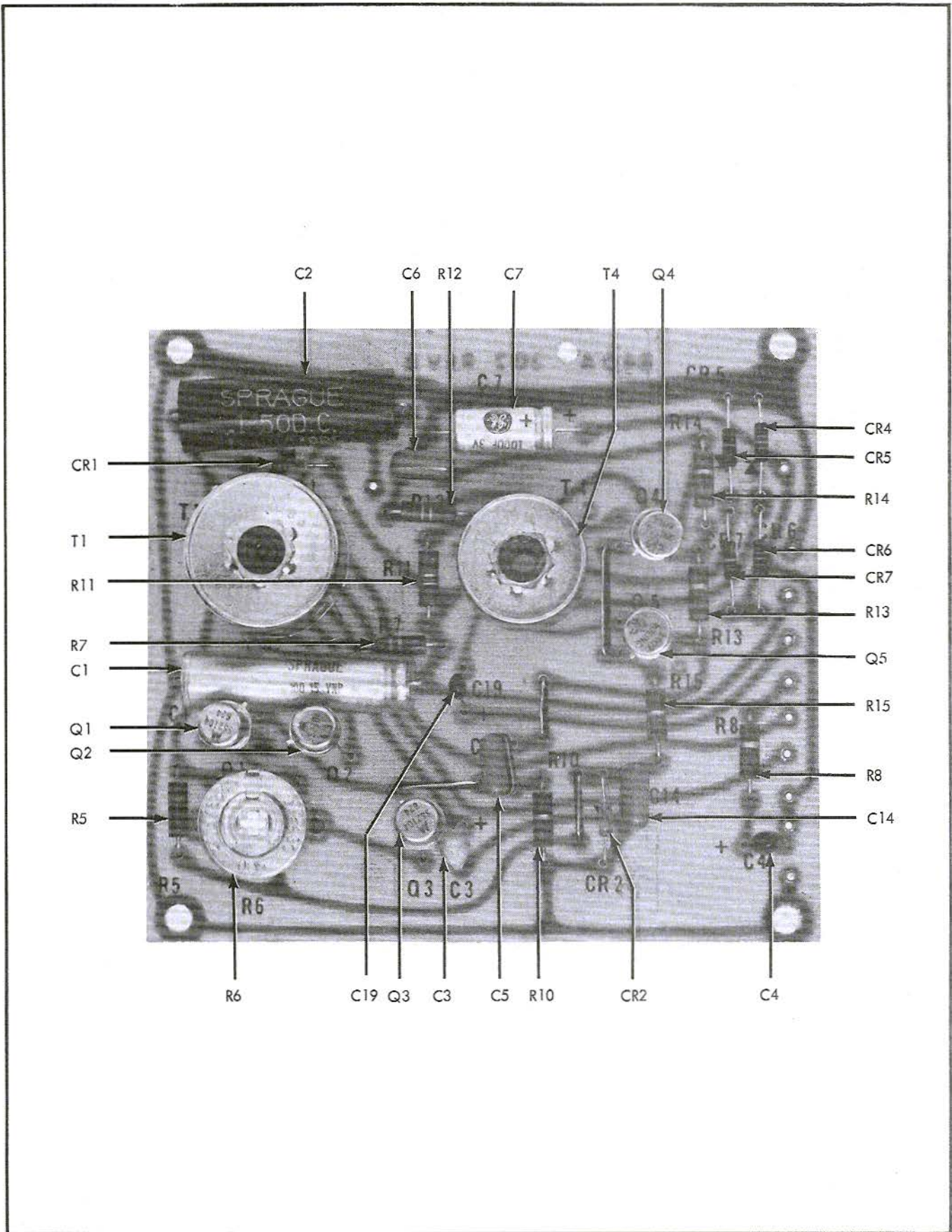

Figure 5-3. OSCILLATOR/SYNCHRONOUS DEMODULATOR

REF DESIG.	DESCRIPTION	FLUKE STOCK NO.	MFR.	MFR. PART NO.	TOT. QTY.	REC. QTY.	USE CODE
	OSCILLATOR/SYNCHRONOUS DEMODULATOR ASSEMBLY Figure 5-3	1702-151597 (840A-402)	89536	1702-151597	1		
C1	Cap, elect, 100 uf +75/-10%, 15v	1502-154914	56289	30D412-6521-C	1	1	
C2	Cap, plstc, 0.01 uf ±10%, 50v	1507-150318	56289	194P1049R5	1		
C3	Cap, Ta, 39 uf ±20%, 6v	1508-163915	06751	TSD2-6-396	1	1	
C4	Cap, Ta, 4.7 uf ±20%, 20v	1508-161943	06751	TSD1-20-475	2	2	
C5, C6	Cap, plstc 0.1 uf ±20%, 250v	1507-161992	73445	C280AE/P100K	3		
C7	Cap, elect, 100 uf +75/-10%, 3v	1502-106534	56289	30D107G003CB4	1	1	
C14	Cap, plstc, 0.1 uf ±20%, 250v	1507-161992	73445	C280AE/P100K	REF		
C19	Cap, Ta, 0.47 uf ±20%, 35v	1508-161349	06751	TSD1-35-474	REF		
CR1, CR2	Diode, type 1N277	4802-150342	93332	1N277	2	2	
CR4&5, CR6&7	Diode, Si, Matched Pair	4802-152918	03877	S2095G	2	1	
Q1, Q2	Tstr, Continental Devices type CDQ10656	4805-203489	07910	CDQ10656	3	1	
Q3	Tstr, Type 2N3053 Tstr, Continental Devices type CDQ10656	4805-150359 4805-203489	95303 07910	2N3053 CDQ10656	1 REF	1	
Q4, Q5	Tstr, type 2N1304	4805-117127	01295	2N1304	2	2	
R5	Res, comp, 75Ω ±5%, 1/2w	4704-108573	01121	EB7505	1		
R6	Res, var, WW, 50Ω ±20%	4702-112490	89536	4702-112490	1		
R7	Res, comp, 120K ±10%, 1/2W	4704-108779	01121	EB1241	1		
R8	Res, comp, 2.2K ±10%, 1/2W	4704-108605	01121	EB2221	REF		
R10	Res, comp, 180Ω ±10%, 1/2W	4704-108571	01121	EB1811	REF		
R11, R12	Res, comp, 18K ±10%, 1/2W	4704-108183	01121	EB1831	2		
R13, R14	Res, comp, 6.8K ±10%, 1/2W	4704-108399	01121	EB6821	2		
R15	Res, comp, 8.2K ±10%, 1/2W	4704-109017	01121	EB8221	1		
T1	Transformer, wire lead	5602-151639	89536	5602-151639	1	1	~I
	Transformer, plug-in	5602-198804	89536	5602-198804	1	1	~Z
T4	Transformer, wire lead	5602-151621	89536	5602-151621	1	1	~I
	Transformer, plug-in	5602-198796	89536	5602-198796	1	1	~Z

REF DESIG.	DESCRIPTION	FLUKE STOCK NO.	MFR.	MFR. PART NO.	TOT. QTY.	REC. QTY.	USE CODE
	MAGNETIC MODULATOR/CARRIER AMPLIFIER ASSEMBLY- Figure 5-4	1702-242495 (540B-410)	89536	1702-165803	REF		
C8	Cap, elect, 300 uf -10/+75%, 3v	1502-151936	56289	30D307GD003- DDO	1	1	
C9	Cap, plstc, 0.047 uf $\pm 10\%$, 50v	1507-150300	56289	194P4739R5	2		
C10	Cap, plstc, 0.047 uf $\pm 10\%$, 250v	1507-162008	73445	C280AE/P47K	2		
C11	Cap, plstc, 0.1 uf $\pm 20\%$, 40v	1507-161992	73445	C280AE/P100K	1		
C12	Cap, Ta, 0.47 uf $\pm 20\%$, 35v	1508-161349	06751	TSD1-35-474	3	1	
C13	Cap, plstc, 0.047 uf $\pm 10\%$, 250v	1507-162008	73445	C280AE/P47K	REF		
C15	Cap, plstc, 0.047 uf $\pm 10\%$, 50v	1507-150300	56289	194P4739R5			
C16, C17	Cap, Ta, 0.47 uf $\pm 20\%$, 35v	1508-161349	06751	TSD1-35-474	REF		
C18	Cap, Ta, 2.2 uf $\pm 20\%$, 20v	1508-161927	06751	TSD1-20-225	1	1	
C20	Cap, mica, 1000 pf $\pm 5\%$, 500v	1504-148387	14655	CD19F102J	REF		Q
L1	Inductor, var, 22 mh, wire lead Inductor, var, 22 mh, plug-in	1800-151654 1800-198788	89536 89536	1800-151654 1800-198788	1	1	I
Q6	Tstr, type 2N1304	4805-117127	01295	2N1304	REF		
Q7	Tstr, type 2N1307	4805-148643	01295	2N1307	2	1	
Q8	Tstr, type 2N1304	4805-117127	01295	2N1304	REF		
Q9	Tstr, type 2N1307	4805-148643	01295	2N1307	REF		
Q10	Tstr, type 2N1304	4805-117127	01295	2N1304	REF		
R3	Res, comp, 12M $\pm 10\%$, 1/2W	4704-152774	01121	EB1261	1		
R16	Res, WW, 100 Ω $\pm 0.03\%$, 1/2W	4702-155846	89536	4702-155846	1		
R17	Res, met flm, 68.1K $\pm 1\%$, 1/2W	4705-161083	75042	Type CEC-TO	1		
R18	Res, met flm, 19.6K $\pm 1\%$, 1/2W	4705-159640	75042	Type CEC-TO	1		
R19	Res, comp, 5.6K $\pm 10\%$, 1/2W	4704-108324	01121	EB5621	1		
R20	Res, comp, 10K $\pm 10\%$, 1/2W	4704-108118	01121	EB1021	1		
R21	Res, met flm, 1.37K $\pm 1\%$, 1/2W	4705-148874	75042	Type CEC-TO	1		
R22	Res, met flm, 750 Ω $\pm 1\%$, 1/2W	4705-150706	75042	Type CEC-TO	1		
R25	Res, comp, 12K $\pm 10\%$, 1/2W	4704-108977	01121	EB1231	REF		
R26	Res, comp, 56K $\pm 10\%$, 1/2W	4704-108472	01121	EB5631	1		
R27	Res, comp, 18K $\pm 10\%$, 1/2W	4704-108183	01121	EB1831	1		
R28	Res, met flm, 2K $\pm 1\%$, 1/2W	4705-151226	75042	Type CEC-TO	1		
R29	Res, comp, 8.2K $\pm 10\%$, 1/2W	4704-109017	01121	EB8221	REF		

REF DESIG.	DESCRIPTION	FLUKE STOCK NO.	MFR.	MFR. PART NO.	TOT. QTY.	REC. QTY.	USE CODE
R30	Res, met flm, 22.1Ω ±1%, 1/2W	4705-151472	75042	Type CEC-TO	1		
R31	Res, comp, 6.8K ±10%, 1/2W	4704-108399	01121	EB6821	REF		
R32	Res, comp, 8.2K ±10%, 1/2W	4704-109017	01121	EB8221	REF		
R33	Res, comp, 4.7K ±10%, 1/2W	4704-108381	01121	EB4721	REF		
R34	Res, comp, 3K ±5%, 1/2W	4704-109090	01121	EB3025	1		
R35	Res, met flm, 200Ω ±1%, 1/2W Res, met flm, 100Ω ±1%, 1/2W	4705-151480 4705-167486	75042 75042	Type CEC-TO Type CEC-TO	1 2		V W
R36	Res, var, WW, 500Ω ±10%, 1/2W Res, var, WW, 600Ω ±5%, 1-1/4W	4702-112433 4702-192179	89536 89536	4702-112433 4702-192179	1 1	1 1	V W
T2	Transformer, wire lead Transformer, wire lead	5602-165837 5602-165845	89536 89536	5602-165837 5602-165845	1 1	1 1	
T3	Transformer, plug-in	5602-198762	89536	5602-198762	1	1	I

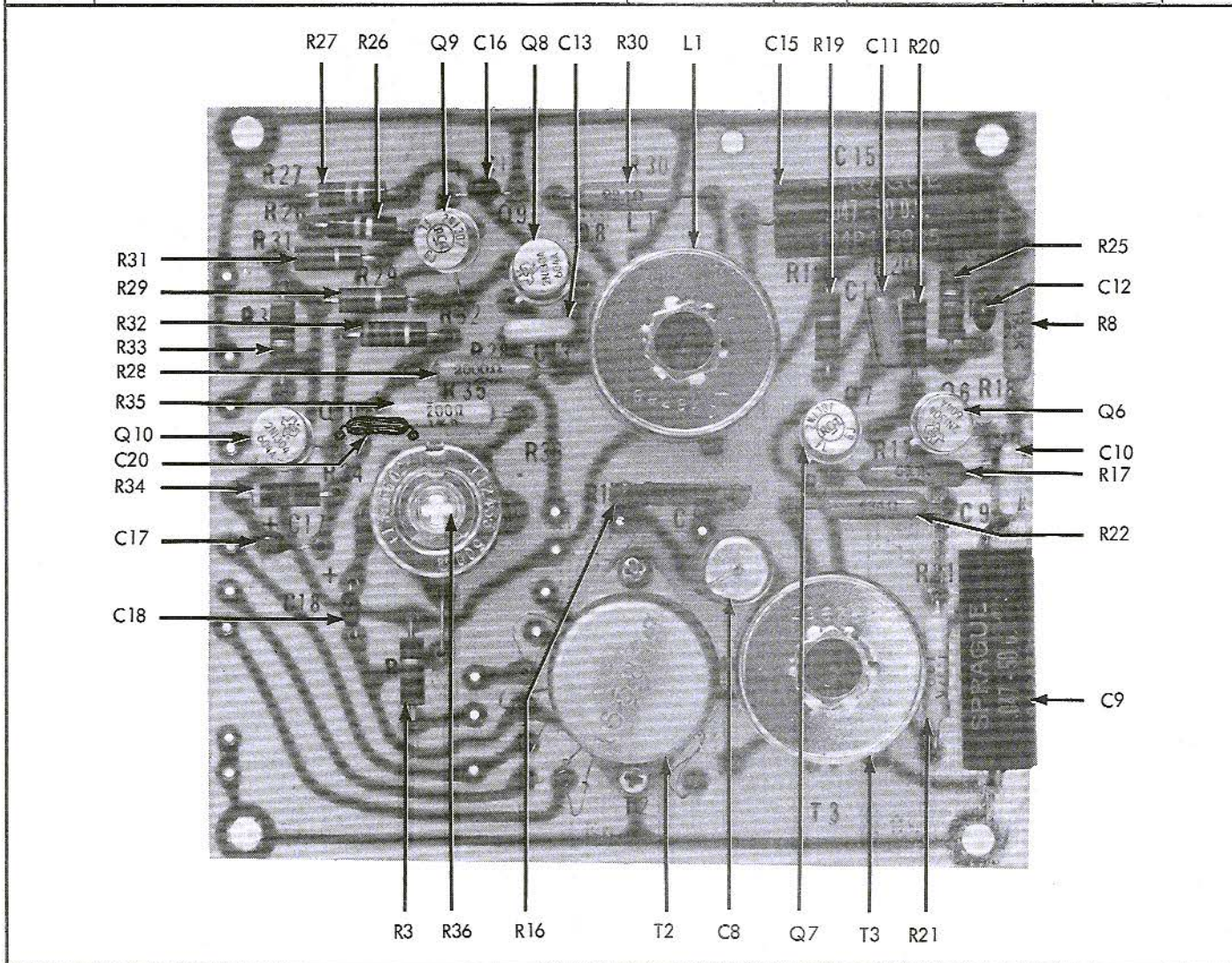



Figure 5-4. MAGNETIC MODULATOR/CARRIER AMPLIFIER ASSEMBLY

REF DESIG.	DESCRIPTION	FLUKE STOCK NO.	MFR.	MFR. PART NO.	TOT. QTY.	REC. QTY.	USE CODE
	SEARCH AND PROTECTION AMPLIFIER ASSEMBLY-Figure 5-5	1702-178186 (540B-401)	89536	1702-178186	REF		
C301	Cap, elect, 15 uf +75/-10%, 6v	1502-105700	56289	30D156G006BA4	1	1	
C302	Cap, elect, 200 uf +75/-10%, 6v	1502-105189	56289	30D207G006DF4	2	1	
C303, C304	Cap, elect, 50 uf +50/-10%, 25v	1502-168823	73445	C426ARF50	2	1	
C305	Cap, var, 170-780 pf, 500v	1509-106245	84171	46-W-469	3		
C306	Cap, cer, 300 pf ±10%, 500v						
C307	Cap, elect, 200 uf +75/-10%, 6v	1502-105189	56289	30D207G006DF4	REF		
C308	Cap, mylar, 0.0047 uf ±20%, 200v	1507-106054	56289	192P47202	1		B
C309	Cap, Ta, 2.2 uf ±20%, 20v	1508-161927	18641	TSD1-20-225	1		
CR301 to CR306	Diode, type 1N270	4802-149187	01295	1N270	6	2	
CR307	Diode, Transitron type S9G	4802-112359	03877	S9G	1	1	A
	Diode, factory treated	4802-178665	89536	4802-178665	2	2	O
	Diode, Transitron type S2055G	4802-233460	03877	S2055G	2	2	P
CR308 CR309	Diode, Transitron type SC6	4802-112383	03877	SC6	2	1	
CR310 to CR313	Diode, Semtech type SS950 (use 4802-200071)	4802-160861	14099	SS950	4	2	C
	Diode, Transitron type SK149	4802-200071	03877	SK149	6	2	X
	Diode, Semtech type SS950	4802-160861	14099	SS950	4	2	Y
CR314	Diode, factory treated	4802-178665	89536	4802-178665	2	2	O
	Diode, transitron type S2055G	4802-233460	03877	S2055G	REF		P
Q301	Tstr, type 2N3565	4805-177105	07263	2N3565	1	1	
	Tstr, Continental Devices type CS23030	4805-159855	07910	CS23030	1	1	H
Q302	Tstr, type 2N2189	4805-144816	01295	2N2189	1	1	
	Tstr, type 2N4126	4805-215897	04713	2N4126	1	1	H
Q303	Tstr, Motorola type SM4144	4805-190389	04713	SM4144	1	1	
Q304	Tstr, Continental Devices type CDQ10656	4805-203489	07910	CDQ10656	REF		
Q305	Tstr, type 2N1304	4805-117127	01295	2N1304	REF		
R301	Res, comp, 10K ±10%, 1/2W	4704-108118	01121	EB1031	REF		
	Res, comp, 10K ±5%, 1/2W	4704-109165	01121	EB1035	REF		R
R302	Res, comp, 33K ±5%, 1/2W	4704-108761	01121	EB3335	1		
R303	Res, comp, 10K ±10%, 1/2W	4704-108118	01121	EB1031	REF		
R304	Res, comp, 16K ±5%, 1/2W	4704-159632	01121	EB1635	2		
R305	Res, comp, 1K ±10%, 1/2W	4704-108563	01121	EB1021	1		
R306	Res, comp, 100Ω ±10%, 1/2W	4704-108100	01121	EB1011	4		
	Res, comp, 100Ω ±5%, 1/2W	4704-188508	01121	EB1015	REF		R
R307	Res, comp, 680Ω ±10%, 1/2W	4704-108712	01121	EB6811	REF		

REF DESIG.	DESCRIPTION	FLUKE STOCK NO.	MFR.	MFR. PART NO.	TOT. QTY.	REC. QTY.	USE CODE
R308	Res, comp, 100Ω ±10%, 1/2W	4704-108100	01121	EB1011	REF		
R309	Res, comp, 100Ω ±5%, 1/2W	4704-188508	01121	EB1015	REF		R
R310	Res, comp, 2.2K ±10%, 1/2W	4704-108605	01121	EB2221	REF		
R311	Res, comp, 2.2K ±5%, 1/2W	4704-108506	01121	EB2225	REF		N
R312	Res, var, WW, 1K ±20%	4702-111575	89536	4702-111575	1		
R313	Res, comp, 22K ±10%, 1/2W	4704-108209	01121	EB2231	1		
R314	Res, comp, 4.7K ±10%, 1/2W	4704-108381	01121	EB4721	REF		B
R315	Res, comp, 47K ±10%, 1/2W	4704-108840	01121	EB4731	REF		
R316	Res, var, WW 100Ω ±20%	4702-112797	89536	4702-112797	1		
R317	Res, comp, 6.2K ±5%, 1/2W	4704-108621	01121	EB6225	2		
R318	Thermistor, 10K at 25° C	4708-104596	02606	JA41J1	1	1	
R319	Res, var, WW, 500Ω ±10%, 1/2W	4702-112433	89536	4702-112433	REF		
R320	Res, met flm, 604Ω ±1%, 1/2W	4705-177154	75042	Type CEC-TO	1		
R320	Res, comp, 100Ω ±10%, 1/2W	4704-108100	01121	EB1011	REF		D



Component selected during calibration. Typical value shown.

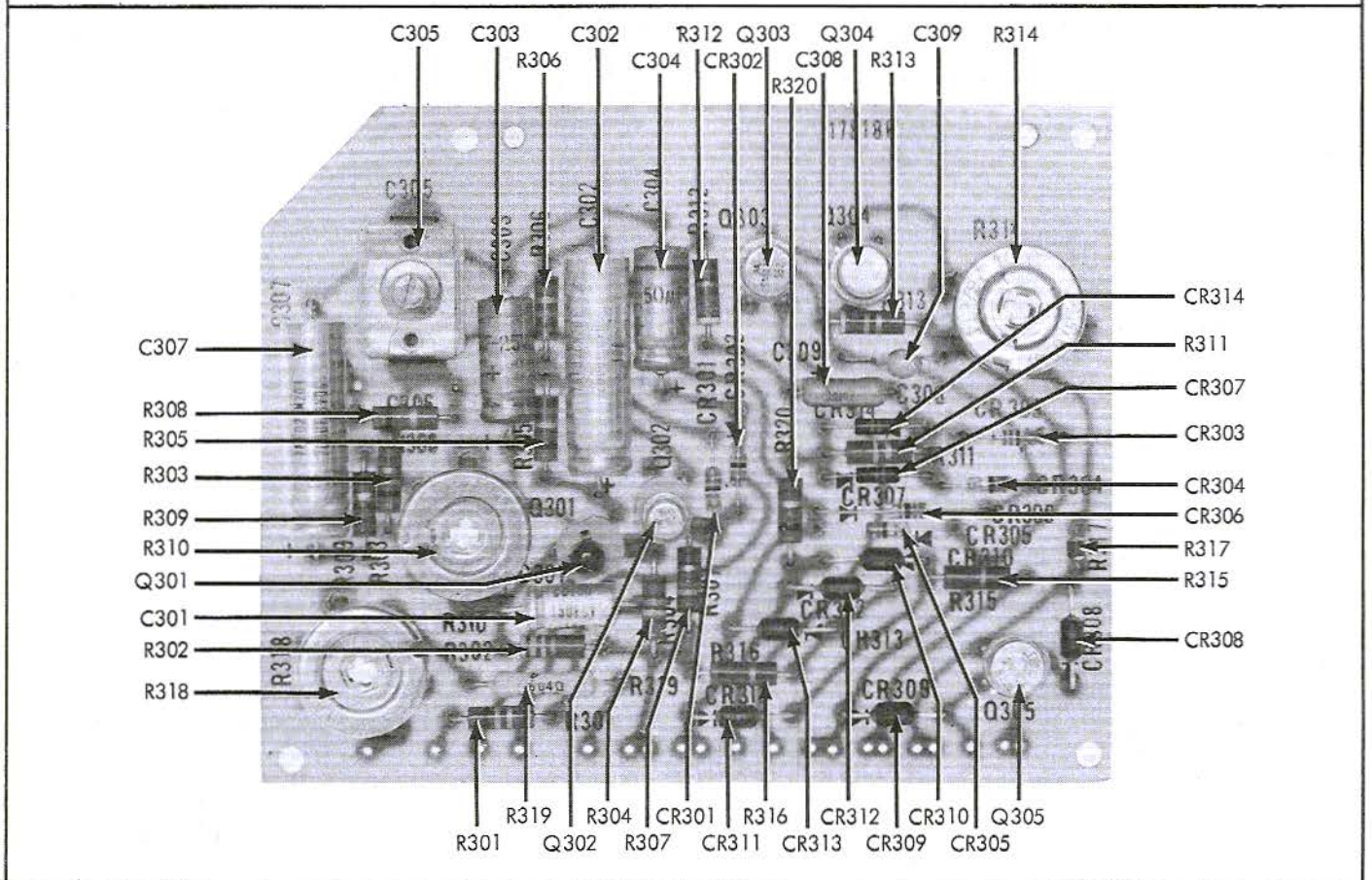

Figure 5-5. SEARCH AND PROTECTION AMPLIFIER ASSEMBLY

REF DESIG.	DESCRIPTION	FLUKE STOCK NO.	MFR.	MFR. PART NO.	TOT. QTY.	REC. QTY.	USE CODE
	A54-1 FINAL ASSEMBLY-Figure 5-6	3158-178152	89536	3158-178152	1		
	A54-2 FINAL ASSEMBLY-Figure 5-6	3158-209163	89536	3158-209155	1		
	A54-1 Panel Assembly (See Figure 5-7)	3158-178095	89536	3158-178095	1		
	A54-2 Panel Assembly (See Figure 5-7)	3158-209155	89536	3158-209155	1		
	Range Switch Assembly (See Figure 5-8)	5110-178103	89536	5110-178103	1		
	Range Board Assembly (See Figure 5-9)	1702-178079 (A54-1-401)	89536	1702-178079	1		
	Compensation Board Assembly (A54-1, See Figure 5-10)	1702-178087	89536	1702-178087	1		
	*Compensation Board Assembly (A54-2, See Figure 5-10)	1702-209148	89536	1702-209148	1		
C801	Cap, cer, 0.01 uf, 1500v	1501-106930	71950	0016-103	1		
K801	Relay, open frame	4504-176354	71482	B-127675	1		
P801	Plug, 24 connection	2105-178004	06473	26-159-24	1		
R802	Res, comp, 1.1K \pm 5%, 1/2W	4704-160432	01121	EB1125	1		
TC801	Thermocouple Assembly	3158-178129	89536	3158-178129	1	1	
	A54 Retaining screw	3153-177477	89536	3153-177477	1		
	Knob	2405-158949	89536	2405-158949	1		
	Retaining washer	2508-177311	79136	5133-25-MD	1		
	Knobs, bar (RANGE and MODE)	2405-170050	89536	2405-170050	2		
	Range switch cover	3206-178459	89536	3206-178459	1		
	Shunt retaining screw	3153-177485	89536	3153-177485	1		
	Holder	2102-103283	71400	4405	1		
	Knob	2405-158949	89536	2405-158949	1		
	Thermocouple cover	1352-177444	89536	3152-177444	1		

* Except that the buss wire, connecting eyelets 1 and 2, is removed and replaced with two red teflon wires for connection to the PROTECTION DISABLE switch on the Model A54-2 front panel, the Model A54-2 and Model A54-1 Compensation Board Assemblies are identical.

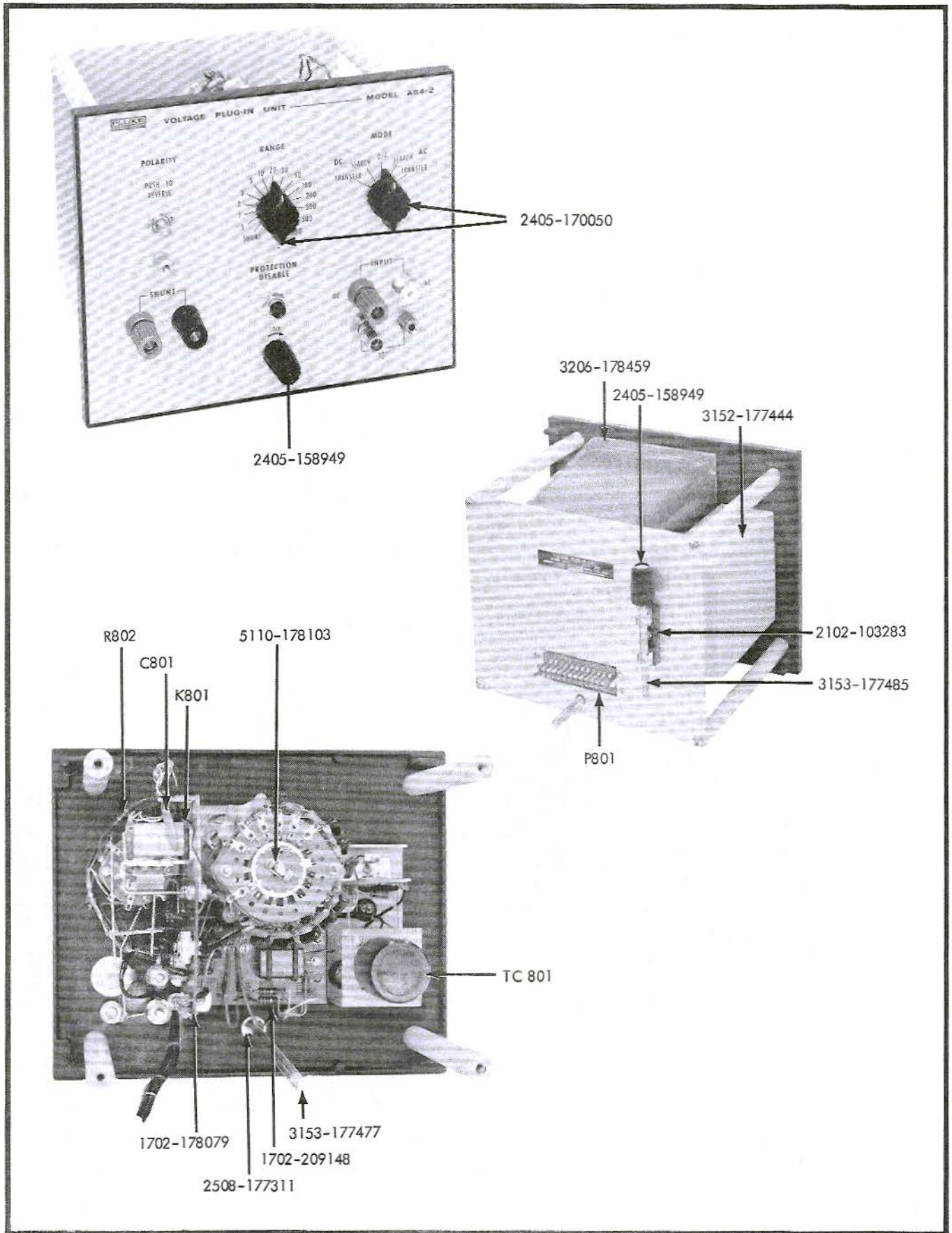

Figure 5-6. A54-1 AND A54-2 FINAL ASSEMBLY

REF DESIG.	DESCRIPTION	FLUKE STOCK NO.	MFR.	MFR. PART NO.	TOT. QTY.	REC. QTY.	USE CODE
	A54-1 Panel Assembly	3158-178095	89536	3158-178095	REF		
J801	A54-2 Panel Assembly	3158-209155	89536	3158-209155	REF		
	Binding post, red	2811-142976	58474	DF31RC	2		
J802	Connector, UHF	2106-102871	91737	6804	1		
J803	Binding post, ground	2811-155911	53474	GP30NC	1		
J804	Connector, ground	2811-102707	89536	2811-102707	1		
	Connector cap	2811-102889	89536	2811-102889	1		
J805	Binding post, red	2811-142976	58474	DF31RC	REF		
J806	Binding post, black	2811-142984	58474	DF31BC	1		
R528	Res, comp, 100Ω ±10%, 1/2W	4704-108100	01121	EB1011	REF		
S801	Switch, rotary (MODE)	5110-178137	89536	5110-178137	1	1	
S802	Switch, push lock	5105-178327	89536	5105-178327	1		
S803	Switch, button type, momentary open (Model A54-2 only)	5104-208850	82389	202-S	1	1	

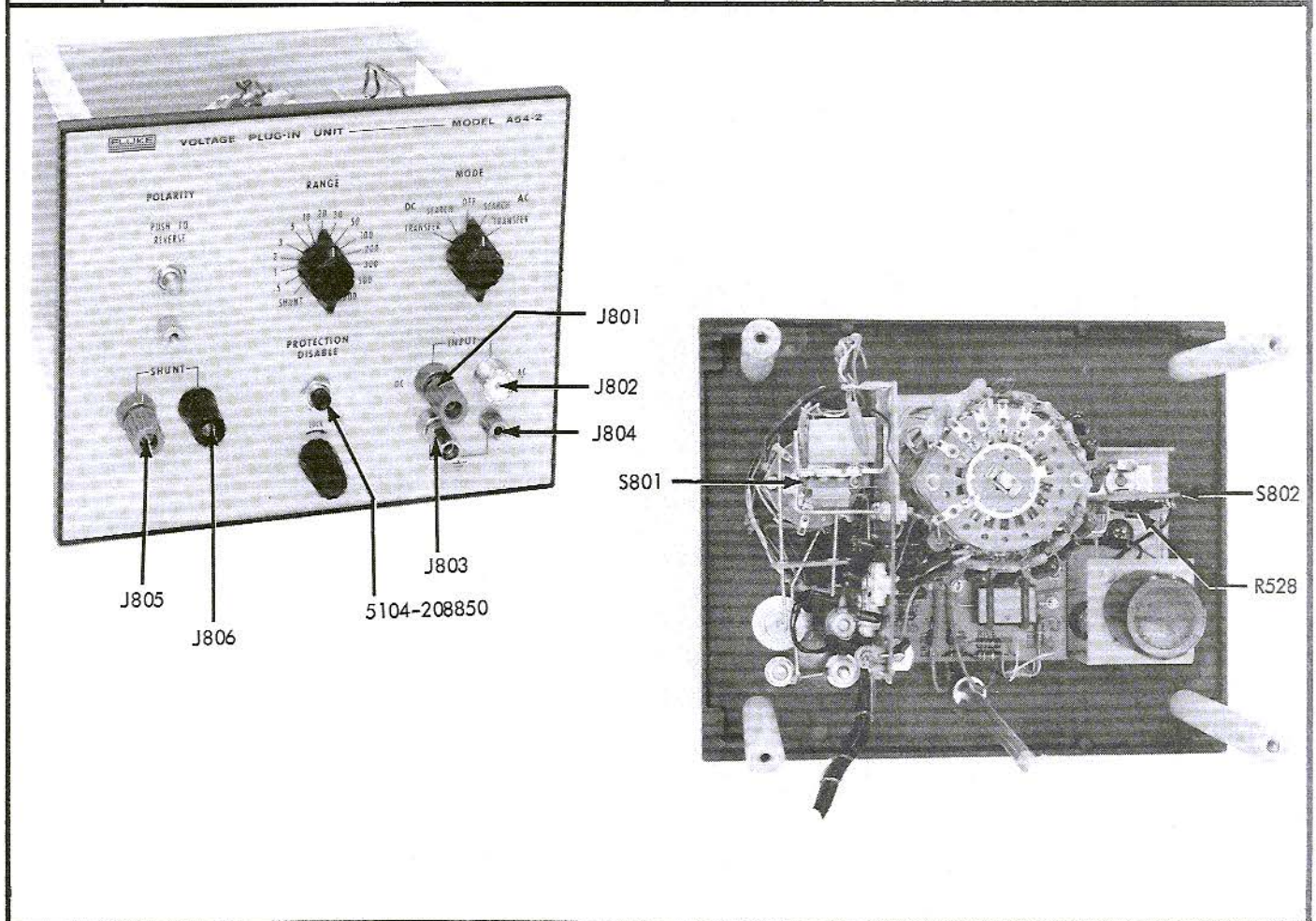

Figure 5-7. PANEL ASSEMBLY

REF DESIG.	DESCRIPTION	FLUKE STOCK NO.	MFR.	MFR. PART NO.	TOT. QTY.	REC. QTY.	USE CODE
	Range Switch Assembly	5110-178103	89536	5110-178103	REF		
C501	Cap, cer, 1.5 pf ± .25 pf, 1000v	1501-178475	56289	10TCC-415-NPO	2		
C502	Cap, cer, 1.5 pf ± .25pf, 1000v	1501-178475	56289	10TCC-415-NPO	REF		
C503	Cap, mica, 2 pf ±5%, 500v	1501-175208	04062	CM-15-020	2		
C504	Cap, mica, 2 pf ±5%, 500v	1501-175208	04062	CM-15-020	REF		
C505	Cap, mica, 5 pf ±10%, 500v	1504-148577	04062	DM15-050	1		
C506	Cap, mica, 15 pf ±5%, 500v	1504-148569	04062	DM15-150	2		
C507	Cap, mica, 56 pf ±5%, 500v	1504-148528	04028	DM15-560	REF		
C508, C509	Cap, mica, 100 pf ±5%, 500v	1504-148494	04062	DM15-101	2		
C510	Cap, mica, 220 pf ±5%, 500v	1504-170423	04062	DM15-221	1		
C511	Cap, mica, 56 pf ±5%, 500v	1504-148528	04062	DM15-560	REF		
C512	Cap, mica, 15 pf ±5%, 500v	1504-148569	04062	DM15-150	REF		
C513	Cap, mica, 10 pf ±10%, 500v	1504-175216	04062	DM15-100			
C514	Cap, mica, 10 pf ±10%, 500v	1					
C515	Cap, mica 2 pf ±10%, 500v	1					
C516	Cap, mica, 5 pf ±10%, 500v	1					
C517	Cap, cer, 3.3 pf ±5%, 1000v	1					
C518	Cap, cer, 1.5 pf ±5%, 1000v	1					
C519	Cap, mica, 5 pf ±10%, 500v	1					
C520	Cap, mica, 220 pf ±5%, 500v	1					
R502	Res, met flm, 1M ±1%, 1W	4705-177188	19701	Type MF8C-TO	1		
R503	Res, met flm, 400K ±1%, 1W	4705-177170	19701	Type MF8C-TO	1		
R504, R505	Res, met flm, 200K ±1%, 1/2W	4705-177196	75042	Type CEC-TO	2		
R506	Res, met flm, 100K ±1%, 1/2W	4705-151316	75042	Type CEC-TO	1		
R507	Res, met flm, 40.2K ±1%, 1/2W	4705-161059	75042	Type CEC-TO	1		
R508, R509	Res, met flm, 20K ±1%, 1/2W	4705-162438	75042	Type CEC-TO	2		
R510	Res, met flm, 10K ±1%, 1/2W	4705-151274	75042	Type CEC-TO	1		
R511	Res, met flm, 4.02K ±1%, 1/2W	4705-167478	75042	Type CEC-TO	1		
R512, R513	Res, met flm, 2K ±1%, 1/2W	4705-151266	75042	Type CEC-TO	1		

REF DESIG.	DESCRIPTION	FLUKE STOCK NO.	MFR.	MFR. PART NO.	TOT. QTY.	REC. QTY.	USE CODE
R514	Res, met flm, 1K $\pm 1\%$, 1/2W	4705-151324	75042	Type CEC-TO	1		
R515	Res, met flm, 100 Ω $\pm 1\%$, 1/2W	4705-167486	75042	Type CEC-TO	REF		
R516	Res, met flm, 301 Ω $\pm 1\%$, 1/2W	4705-167494	75042	Type CEC-TO	1		
R517	Res, met flm, 499 Ω $\pm 1\%$, 1/2W	4705-151514	75042	Type CEC-TO	1		
R518	Res, met flm, 909 Ω $\pm 1\%$, 1/2W	4705-178053	75042	Type CEC-TO	1		
R519	Res, met flm, 1.91K $\pm 1\%$, 1/2W	4705-177212	19701	Type MF7C-TO	1		
R520	Res, WW, 3.9K $\pm 1\%$, 1/2W	4707-169250	89536	4707-169250	1		
R521	Res, WW, 5.9K $\pm 1\%$, 1W	4707-169243	89536	4707-169243	1		
R522	Res, WW, 10K $\pm 1\%$, 1W	4707-131664	89536	4707-131664	1		
R523	Res, WW, 20K $\pm 1\%$, 1W	4707-131680	89536	4707-131680	1		
R524	Res, WW, 40K $\pm 1\%$, 1W	4707-146530	89536	4707-146530	1		
R525	Res, WW, 60K $\pm 1\%$, 10W	4706-177139	14193	Type SP-1127	1		
R526	Res, WW, 100K $\pm 1\%$, 10W	4706-177121	14193	Type SP-1127	1		
R527	Res, WW, 200K $\pm 1\%$, 10W	4706-177113	14193	Type SP-1127	1		

 Component selected during calibration. Typical value shown.

Figure 5-8. RANGE SWITCH ASSEMBLY



TOP VIEW

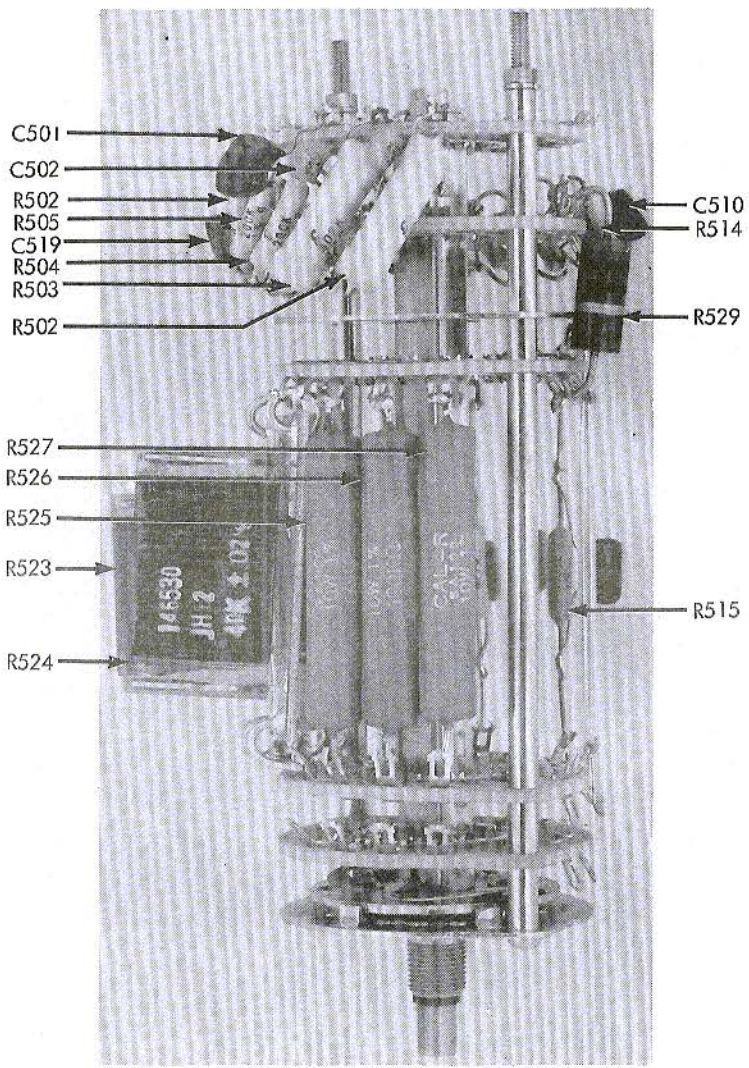
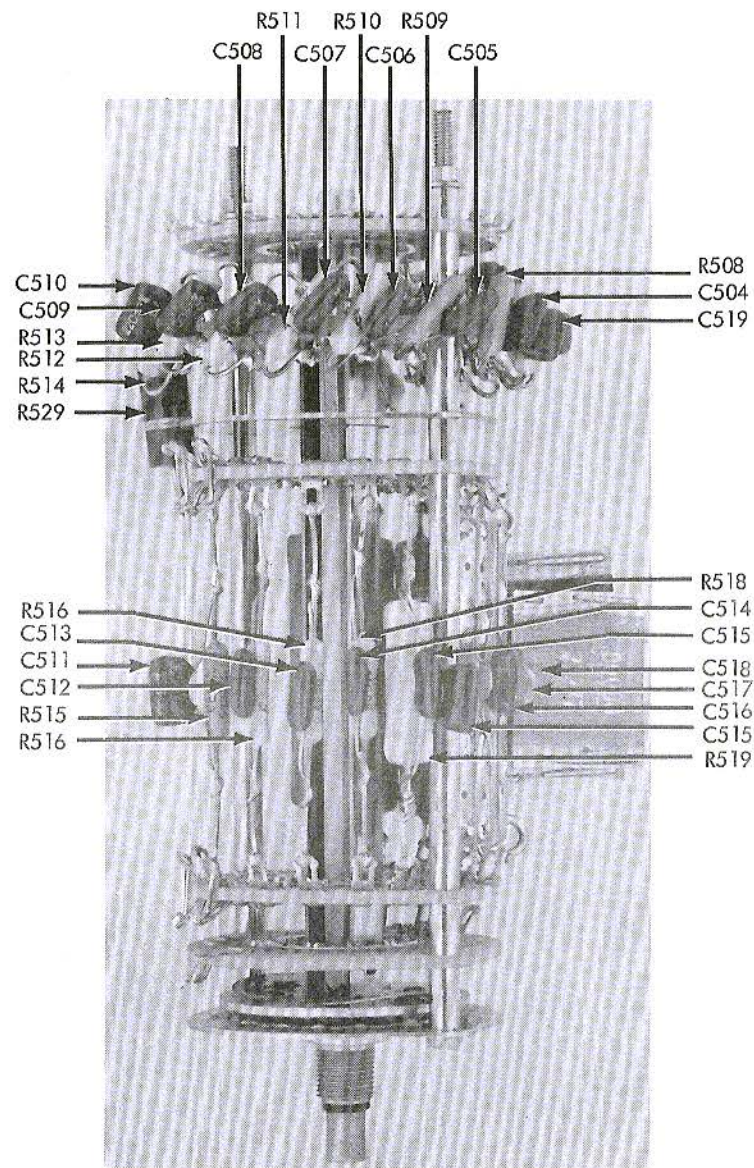

BOTTOM VIEW

REF DESIG.	DESCRIPTION	FLUKE STOCK NO.	MFR.	MFR. PART NO.	TOT. QTY.	REC. QTY.	USE CODE
	Range Board Assembly	1702-178079	89536	1702-178079	REF		
C601	Cap, mica, 680 pf $\pm 5\%$, 500v	1					S
	Cap, mica, 680 pf $\pm 5\%$, 500v	1504-148403	14655	CD19F681J	1		T
C602	Cap, mica, 820 pf $\pm 5\%$, 500v						S
	Cap, mica, 1000 pf $\pm 5\%$, 500v	1504-148387	14655	CD19F102J	REF		T
C603	Cap, var, 80 to 480 pf	1509-168112	02799	46-W-466	3		S
	Cap, var, 170 to 780 pf, 175v	1509-106245	84171	46-W-469	REF		T
C604	Cap, mica, 1800 pf $\pm 5\%$, 500v	1					
C605	Cap, var, 80 to 480 pf	1509-168112	02799	46-W-466	REF		
C606	Cap, mica, 2200 pf $\pm 5\%$, 500v				REF		S
	Cap, mica, 820 pf $\pm 5\%$, 500v	1504-226167	14655	CD19F821F500	1		T
C607	Cap, var, 80 to 480 pf	1509-168112	02799	46-W-466	REF		M
	Cap, var, 170 to 780 pf, 175v	1509-106245	84171	46-W-469	REF		T
C608	Cap, mica, 10 pf $\pm 10\%$, 500v	1504-175216	04062	DM15-100	1		D
DS601	Spark gap, 90v $\pm 10\%$	5109-198507	95984	B1-F90			
R601, R602	Res, comp. $2.7\Omega \pm 5\%$, 1W	4704-159376	01121	GB27G5	2		D



Component selected during calibration. Typical value shown.

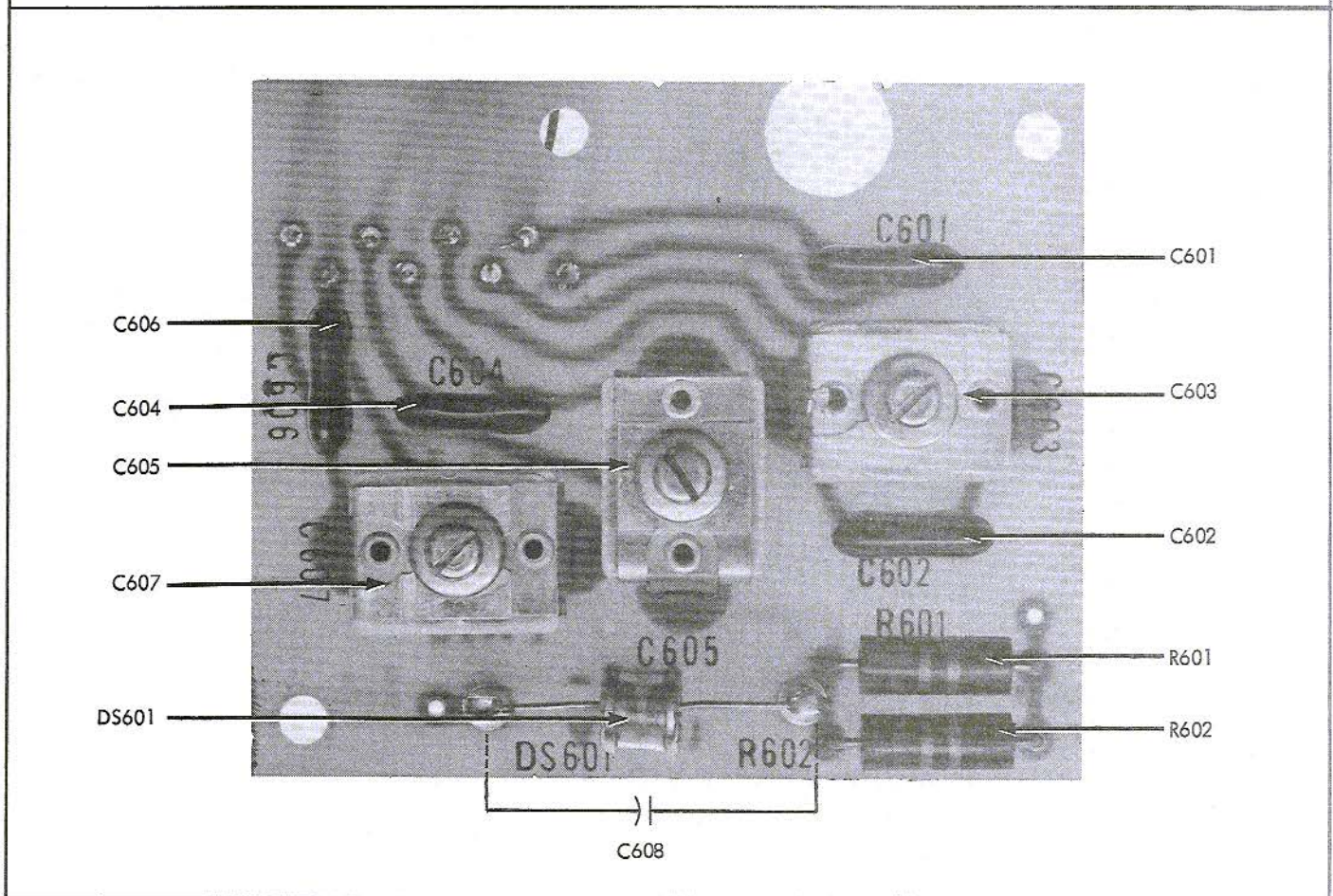

Figure 5-9. RANGE BOARD ASSEMBLY

REF DESIG.	DESCRIPTION	FLUKE STOCK NO.	MFR.	MFR. PART NO.	TOT. QTY.	REC. QTY.	USE CODE
	Compensation Board Assembly						
	A54-1	1702-178087	89536	1702-178087	REF		
	A54-2	1702-209148	89536	1702-209148	REF		
C701	Cap, mica, 1800 pf $\pm 5\%$, 500v	1					
CR701,	Diode, matched pair	4802-182592	89536	4802-182592	1		
CR702	Diode, matched pair	4802-182592	14552	MB7025	1		
CR703,	Diode, factory treated	4802-200741	89536	4802-200741	2		S
CR704	Diode, Transatron type SK-149	4802-200071	03877	SK-149	REF		T
K701	Relay, reed	4501-185371	89536	4501-185371	1		C
	Relay, reed	4501-196667	89536	4501-196667	1		D
	Bobbin Assembly	3158-178145	89536	3158-178145	1		
R701	Res, comp, 100 Ω $\pm 10\%$, 1/2W	4704-108100	01121	EB1011	1		
	Res, comp, 150 Ω $\pm 5\%$, 1/2W	4704-186056	01121	EB1515	1		
R702	Res, comp, 10 Ω $\pm 10\%$, 2W	4704-110163	01121	HB1001	1		
R703	Res, comp, 1K $\pm 10\%$, 1/2W	4704-108563	01121	EB1021	1		
R704	Res, comp, 100 Ω $\pm 10\%$, 1/2W	4704-108100	01121	EB1011	1		
R705	Res, comp, 6.2K $\pm 5\%$, 1/2W	4704-108621	01121	EB6225	2		C
	Res, comp, 3.3K $\pm 10\%$, 1/2W	4704-108373	01121	EB3321	1		D
R706	Res, comp, 6.2K $\pm 5\%$, 1/2W	4704-108621	01121	EB6225	2		C
	Res, comp, 1.2K $\pm 10\%$, 1/2W	4704-108803	01121	EB1221	1		D



Component selected during calibration. Typical value shown.

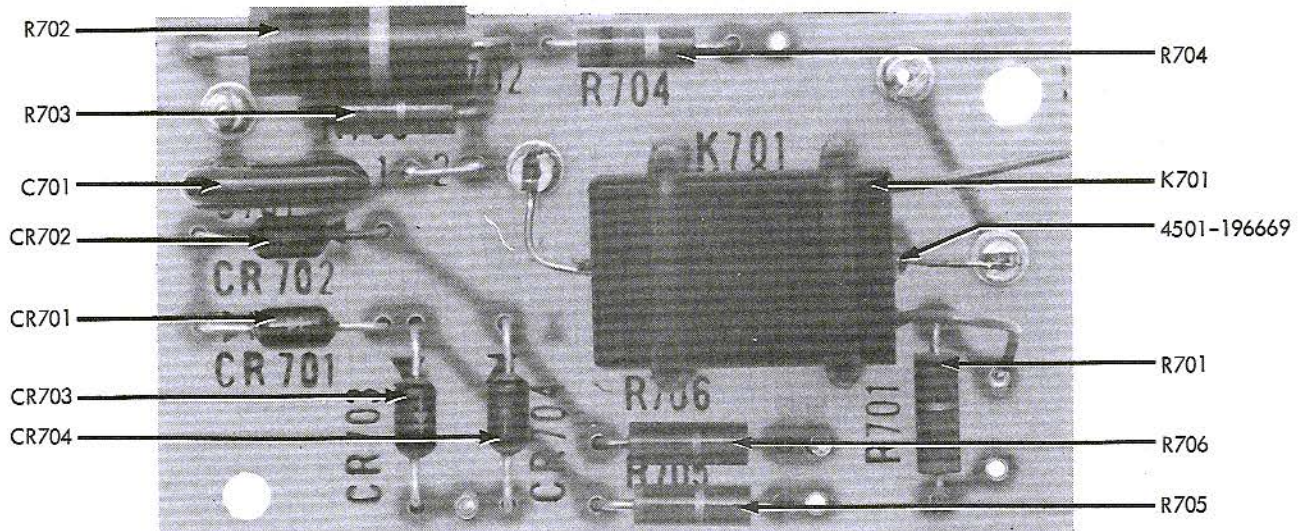

Figure 5-10. COMPENSATION BOARD ASSEMBLY

REF DESIG.	DESCRIPTION	FLUKE STOCK NO.	MFR.	MFR. PART NO.	TOT. QTY.	REC. QTY.	USE CODE
	RECHARGEABLE BATTERY PACK (See Figure 5-11)	3158-227017 (540B-504)	89536	3158-227017			AB
A1	Rectifier P/C Assembly (See Figure 5-11)	1702-227082 (540B-409)	89536	1702-227082	1		
BT1, BT2	Battery, 1.2v, Ni Cad	4002-160390	05397	N53T	20		
BT3	Battery, 1.35v, mercury	4002-103226	05397	E42N	1		
DS1	Lamp, neon, 115 vac, Type AIC (not illustrated)	3903-193524	08717	858-R-AIC-68K	1	1	
F1	Fuse, Type MDL, slow blow, 1/4 amp, 250v (for 115v operation) (not illustrated)	5101-166306	71400	Type MDL	1	2	
F1	Fuse, Type MDL, slow blow, 1/8 amp, 250v (for 230v operation) (not illustrated)	5101-166488	71400	Type MDL	1	2	
J1	Connector, male, 3 contact, chassis mount	2109-222612	82389	AC3G	1		
T1	Transformer, power	5601-227090	89536	5601-227090	1		
XB1	Holder, battery	2102-227058	89536	2102-227058	1		
XB2	Holder, battery	2102-227066	89536	2102-227066	1		
XF1	Holder, fuse	2102-160846	75915	342004	1		
1	Lock, battery holder	2102-103689	11503	#63	1		
2	Line cord (not illustrated)	6005-226100	91934	18/35VT-350-1	1		

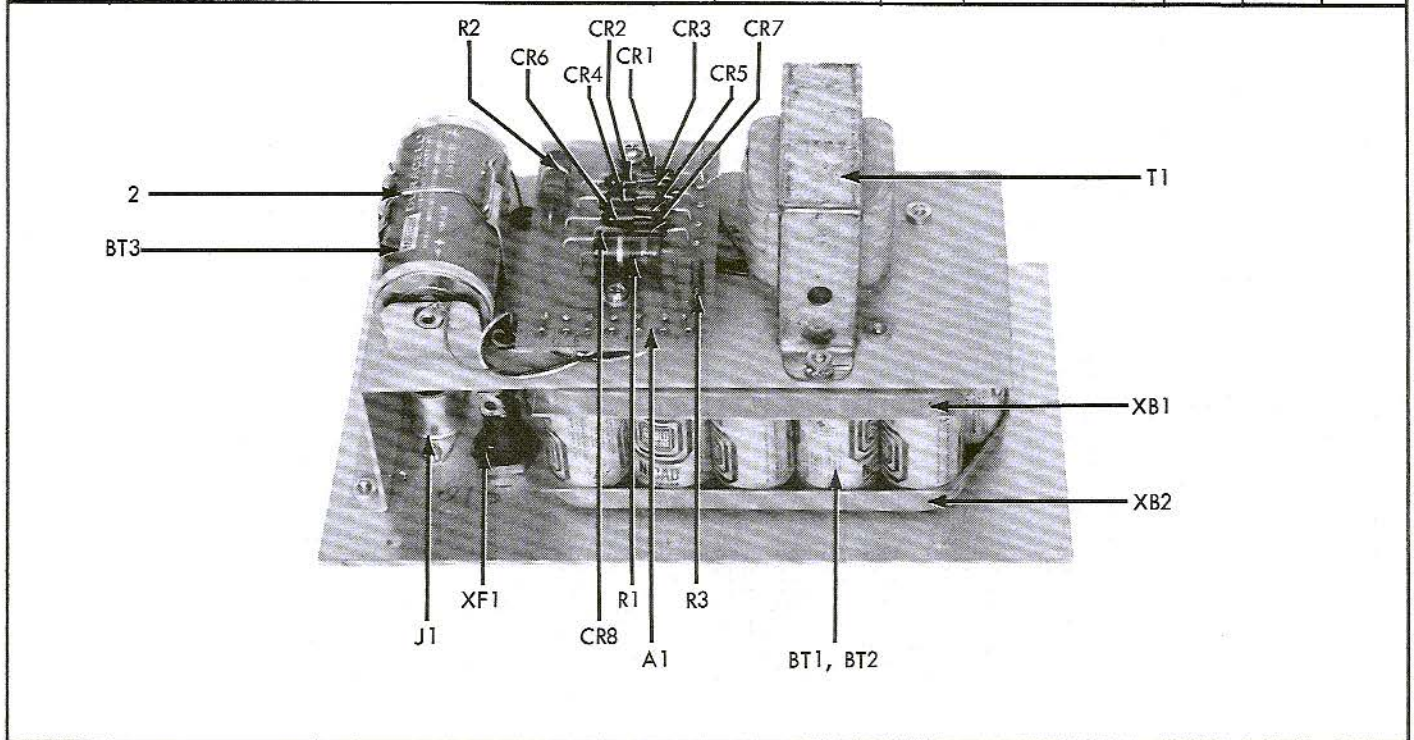

Figure 5-11. 540B-110 RECHARGEABLE BATTERY PACK

REF DESIG.	DESCRIPTION	FLUKE STOCK NO.	MFR.	MFR. PART NO.	TOT. QTY.	REC. QTY.	USE CODE
CR1 thru CR8	Rectifier P/C Assembly (See Figure 5-11)	1702-227082 (540B-409)	89536	1702-227082	REF		
R1, R2	Diode, Type 1N4817	4802-116111	05277	1N4817	8	2	
R3	Res, comp, $56\Omega \pm 10\%$, 2W	4704-110221	01121	HB5601	2		
	Res, comp, $6.8\Omega \pm 5\%$, 1/2W	4704-218750	01121	EB68G5	1		

5-8. SERIAL NUMBER USE CODES

Alphabetical codes appearing in the use code column identify applicable serial number ranges (See paragraph 5-3h). These ranges and their codes are listed below.

USE CODE	APPLICABLE SERIAL NUMBERS
No Code	Model 540B serial number 123 and on. Model A54-1 serial number 123 and on. Model A54-2 serial number 339 and on.
AA	Model 540B serial number 123 thru 928.
AB	Model 540B serial number 929 and on.
A	Model 540B serial number 123 to 148
B	Model 540B serial number 149 and on.
C	Model 540B serial number 123 to 258 Model A54-1 serial number 123 to 258
D	Model 540B serial number 259 and on. Model A54-1 serial number 259 and on.
E	Model 540B serial number 123 to 188
F	Model 540B serial number 189 to 218
G	Model 540B serial number 219 thru 653.
H	Model 540B serial number 320 and on.
I	Model 540B serial number 123 thru 299.
J	Model 540B serial number 11 to 123.
K	Model 540B serial number 123 to 300 and 321.
L	Model 540B serial number 301 to 320 and 322 and on.
M	Model A54-2 serial numbers 476 thru 618.
N	Model 540B serial number 579 and on.
O	Model 540B serial numbers 149 thru 641.
P	Model 540B serial number 642 and on.
Q	Model 540B serial number 639 and on.
R	Model 504B serial number 632 and on.
S	Model A54-2 serial numbers 123 thru 618.
T	Model A54-2 serial number 619 and on.
U	Model 540B serial number 654 and on.
V	Model 540B serial numbers 123 thru 653.
W	Model 540B serial number 654 and on.
X	Model 540B serial numbers 259 thru 629.
Y	Model 540B serial number 630 and on.
Z	Model 540B serial number 300 and on.

SECTION VI

ACCESSORIES

6-1. MODEL A55 THERMAL CONVERTERS

6-2. INTRODUCTION

6-3. Nine Fluke Model A55 Thermal Converters (Figure 6-3) are available with ratings of 0.5, 1, 2, 3, 5, 10, 20, 30, and 50 volts, each of which may be used from 1/2 to 1 times the rating. These converters make possible extremely accurate thermal-transfer ac measurements from sub-audio frequencies to the VHF region. AC/DC difference of the Model A55 series is comparable to that of theoretical standards maintained by the National Bureau of Standards.

6-4. CONSTRUCTION

6-5. A specially constructed thermocouple, selected for frequency characteristics and low DC reversal error, is the thermally responsive element of the Model A55 series. AC and dc input voltages are applied directly across the thermocouple heater on the 0.5 volt model. For higher voltages, low temperature coefficient metal-film resistors provide the proper range multipliers.



Figure 6-1. MODEL A55 THERMAL CONVERTERS AND ACCESSORIES

6-6. SPECIFICATIONS

RANGE

0.5, 1, 2, 3, 5, 10, 20, 30, and 50 volts

NOTE: Each converter may be used from 1/2 to 1 times voltage rating.

AC/DC DIFFERENCE CONVERTER	1 MHz	10 MHz	30 MHz	50 MHz
0.5v	±0.01%	+0.10%	+0.60%	+1.50%
1 - 10v	±0.01%	±0.03%	±0.10%	±0.10%
20 - 50v	±0.01%	±0.05%	±0.10%	---

CALIBRATION

Calibration of the Model A55 is referenced to the center of a GR 874-TL coaxial tee attached to the converter input connector. Each range is adjusted to be within the above deviations from zero error as defined by reference standards maintained by the John Fluke Standards Laboratory and periodically calibrated by the National Bureau of Standards. These ac/dc difference figures do not include the National Bureau of Standards random and systematic error uncertainties. The 0.5 volt Model A55 is supplied with a test report indicating deviations to the nearest 0.01% at the above frequencies. John Fluke Standards Laboratory or National Bureau of Standards test reports are available at extra cost.

REVERSAL ERROR

Less than 0.025%.

INPUT IMPEDANCE

Approximately 200 ohms/volt.

OUTPUT VOLTAGE

7 millivolts nominal at rated input.

OUTPUT RESISTANCE

8 ohms nominal.

INPUT CONNECTOR

GR type 874-L.

OUTPUT CONNECTOR

Amphenol 80-PC2M 2-pin, microphone type.

SIZE AND WEIGHT

Converter	Diameter	Length	Weight
0.5v	1-3/8"	3-5/16"	10 oz.
1v, 2,	1-3/8"	5-3/16"	13 oz.
3v, 5,	1-3/8"	6-1/2"	15 oz.
10v, 20v	1-3/8"	7-1/16"	1 lb.
30v, 50v	1-3/8"	7-1/16"	1 lb.

6-7. ACCESSORIES

6-8. Model A55-110 Accessory Kit is recommended for use with Model A55 Thermal Converters in virtually any calibration or measurement setup. The kit includes:

a. Coaxial tee for Model A55 input (GR type 874-TL).

- b. Three coaxial adapters for Model A55 input (GR type 874 to UHF, BNC, and type N jacks).
- c. Interconnecting coaxial cable, ac source to coaxial tee.
- d. To store the Model A55 Thermal converters and accessories, a Model C55 case with a molded high impact styrene insert is available (see Figure 6-1). The Model C55 is designed to accommodate a complete set of nine converters.

6-9. MODEL A40 AND A40A CURRENT SHUNTS

6-10. INTRODUCTION

6-11. Models A40 and A40A Current Shunts (see Figure 6-2) are designed to convert the Model 540B Thermal Transfer Standard to a rms current measuring device over a 2.5 milliamperere to 20 ampere range, with a frequency response from 5 Hz to 100 kHz. The A40 shunts covering the range of 10 milliamperes to 5 amperes plug into the SHUNT terminals of the Model A54 Voltage Plug-In Unit of the Model 540B Thermal Transfer Standard, and electrically shunt the heater of the thermal converter. The A40A shunts (10 amperes and 20 amperes) are connected to the SHUNT terminals by a special cable, part number 6002-212860 (see Figure 6-3). Thus, the nominal heater current rating of 5 ma is maintained at the nominal current shunt rating. Each shunt is useful from 1/2 to 1 times its nominal rating. With no shunt in place, the 5 ma heater rating of the Model 540B thermal converter allows current transfers from 2.5 ma to 5 ma.

6-12. CONSTRUCTION

6-13. Internal construction of the shunts includes straight-wire, bifilar-wound ribbon, and folded-ribbon resistive elements, depending on shunt size. The resistive elements are in good thermal contact with the shunt case, which in the larger shunts is an efficient finned-aluminum extrusion.

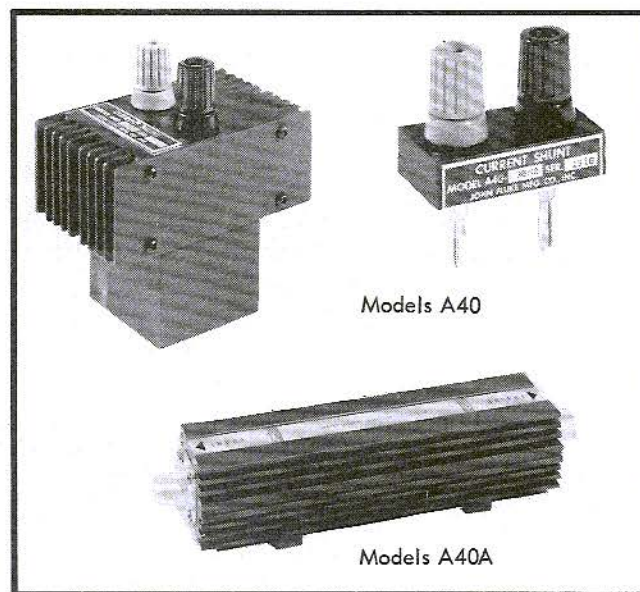

Figure 6-2. CURRENT SHUNTS

6-14. SPECIFICATIONS

CURRENT RATINGS

10, 20, 30, 50, 100, 200, 300, and 500 milliamperes; 1, 2, 3, 5, 10, and 20 amperes.

NOTE. Each shunt may be used from 1/2 to 1 times nominal rating.

OVERALL CURRENT RANGE

2.5 milliamperes to 20 amperes. (5 ma nominal rating of the Model A54 thermal converter heater allows current transfers from 2.5 ma to 5 ma without shunts.)

ACCURACY (% of input)

The following also applies to the Model 540B thermal converter heater, for current transfers from 2.5 to 5 ma.

SHUNT	FREQUENCY	AC/DC DIFFERENCE
10 ma through 20a	5 Hz - 20 kHz	±0.02%
	20 kHz - 50 kHz	±0.03%
10 ma through 5a	50 kHz - 100 kHz	±0.05%

CALIBRATION

Each range is adjusted to be within the above deviations from zero error as defined by reference standards maintained by the John Fluke Standards Laboratory and periodically calibrated by the National Bureau of Standards. These ac/dc difference figures do not in-

clude the National Bureau of Standards random and systematic error uncertainties. John Fluke Standards Laboratory or National Bureau of Standards test reports are available at extra cost.

6-15. ACCESSORIES

6-16. Optional accessories include the following:

- a. A Model C41 case (see Figure 6-3), manufactured of ABS plastic with polyurethane foam cushion, for transporting and storing a complete set of shunts.
- b. A Model A45 Current Transfer Switch (see Figure 6-3). This switch is designed for convenience in current measurement to eliminate the process of interchanging AC and DC leads to the current shunt. Two cable assemblies are supplied with the Model A45 Current Transfer Switch (see Figure 6-3). One cable, Fluke part number 6002-212860, is used for connecting a Model A40A shunt to the Model A54 SHUNT terminals, or can be used to connect the Model A45 Current Transfer Switch to a Model A40 shunt. The other cable, Fluke part number 6002-212852, is used to connect a Model A40A shunt to the Model A45 Current Transfer Switch. See Figure 2-8 for an illustration showing the interconnection of the above cables in conjunction with the Model A45 Current Transfer Switch, the Model A54, and the current shunts.

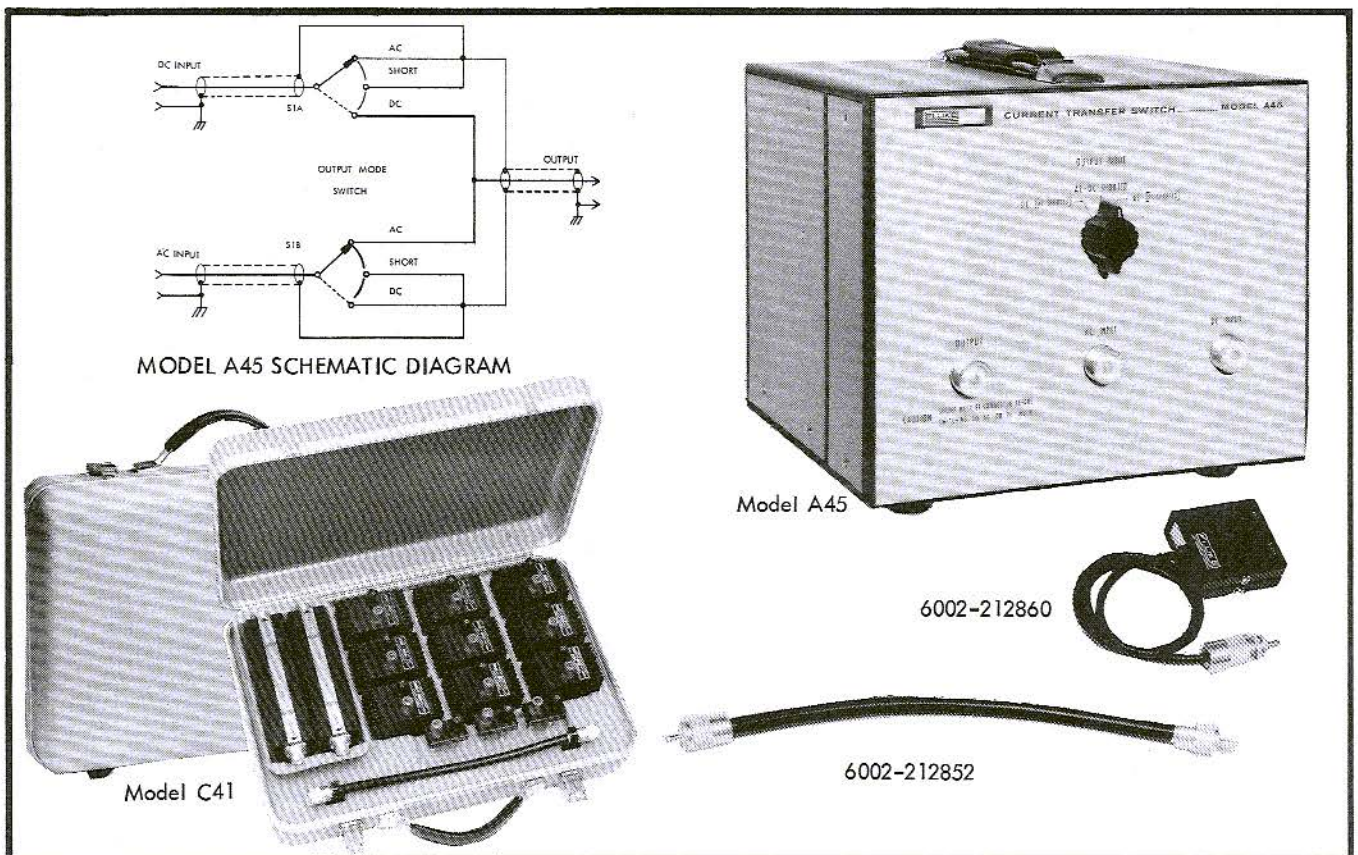
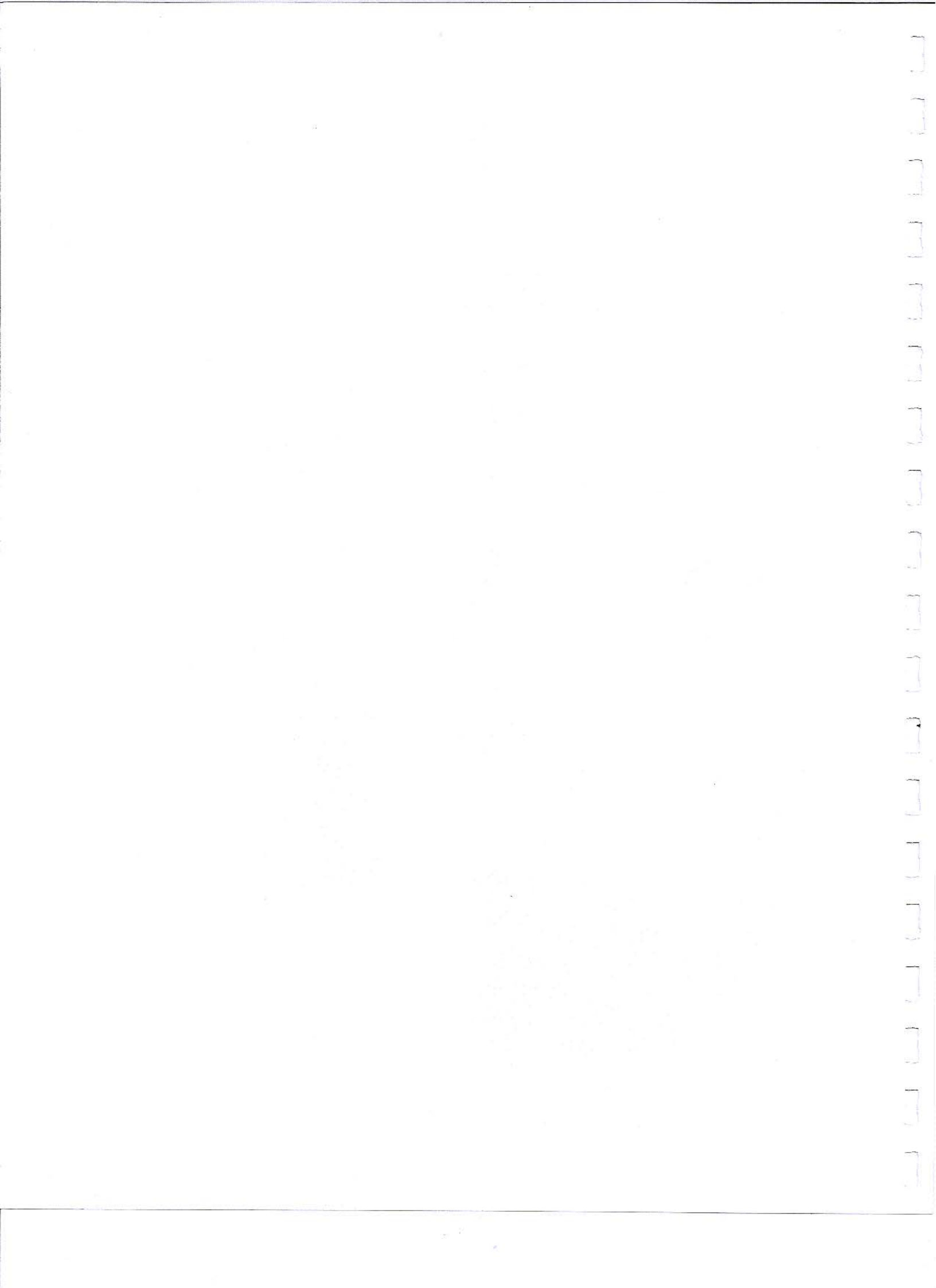
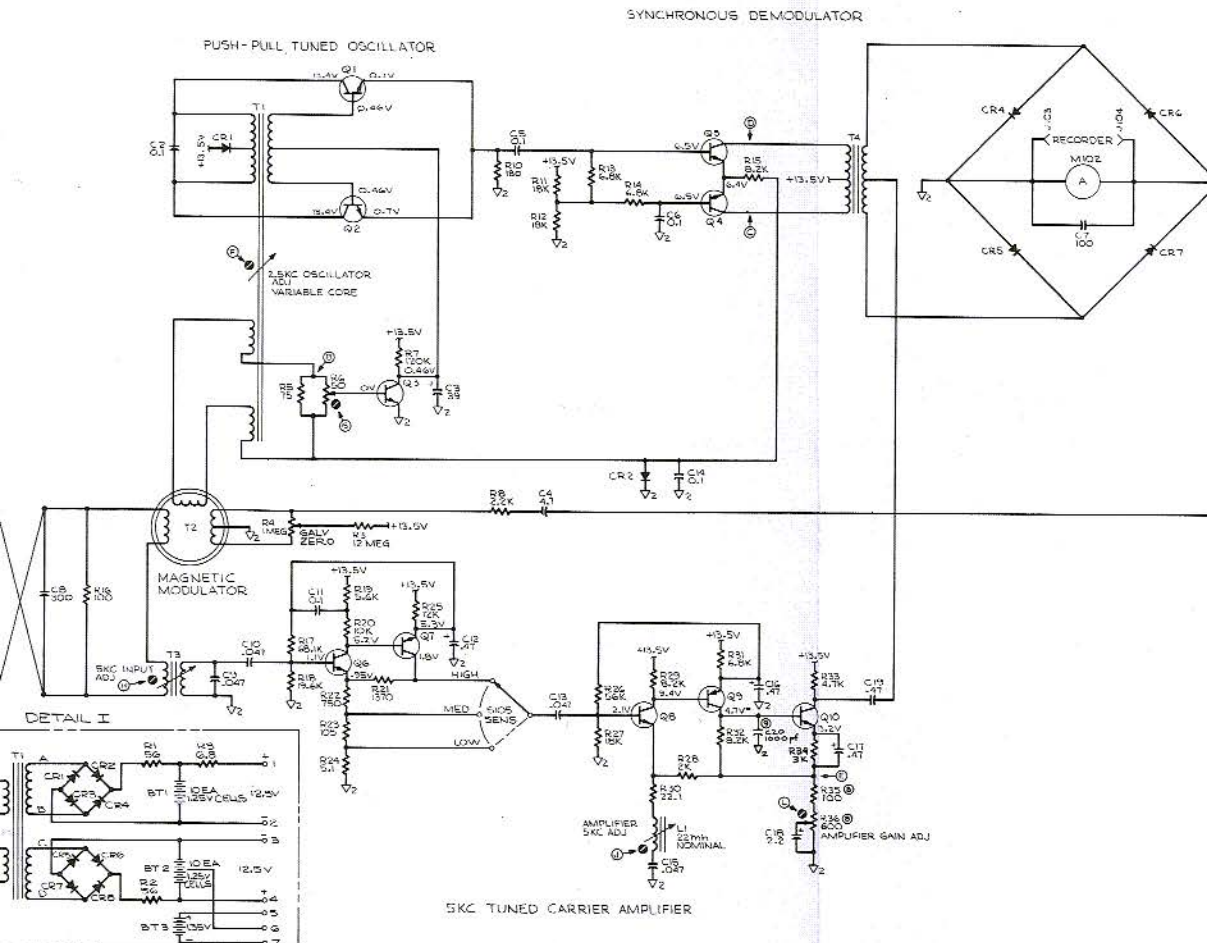
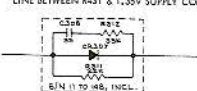

Figure 6-3. CURRENT SHUNT ACCESSORIES





- CHANGES:
- ① FOR S/N 11 TO 122
R40 (662) WAS USED IN PLACE OF CONNECTING LINE BETWEEN R41 & 1.35V SUPPLY COMMON
 - ② 
 - ③ R320 ADDED AT S/N 259
 - ④ R401 CHANGES:
S/N 123 THRU 188 - 51K
S/N 189 THRU 218 - 47K
S/N 219 AND ON - 39K
S/N 654 AND ON - 5K VAR.
 - ⑤ R402 CHANGES:
S/N 123 THRU 188 - 51K
S/N 189 THRU 218 - 47K
S/N 219 AND ON - 39K
S/N 654 AND ON - 5K VAR.
 - ⑥ R452 AND R453 CHANGES:
S/N 11 THRU 122 - 15K
S/N 123 AND ON - 12K
 - ⑦ R457 CHANGES:
S/N 11 THRU 122 - 480
S/N 123 THRU 300 & S/N 321 - 270
S/N 301 THRU 320 & 322 & ON - 180
 - ⑧ FOR S/N 123 THRU 653:
R35 WAS 200Ω
R34 WAS 500Ω
 - ⑨ C20 ADDED AT S/N 639
 - ⑩ NON-RECHARGEABLE BATTERIES DELETED AND CIRCUIT OF DETAIL I MADE STANDARD AT S/N 929 AND UP.

- NOTES:
1. UNLESS OTHERWISE INDICATED RESISTANCES ARE IN OHMS, AND CAPACITANCES ARE IN MICROFARADS
 2. ALL VOLTAGES SHOWN ARE DC AND ARE REFERENCED TO THE CHASSIS. VOLTAGES MAY VARY UP TO 20%
 3. Ⓢ INDICATES INTERNAL ADJUSTMENTS
 4. ○ INDICATES TEST POINTS AND INTERNAL ADJUSTMENTS
 5. Ⓜ INDICATES 1.35V SUPPLY COMMON
 6. Ⓜ INDICATES 13.5V SUPPLY COMMON
 7. * FACTORY SELECTED, NOMINAL VALUE SHOWN
 8. Ⓜ INDICATES COMMON GROUND CONNECTION TIED TO PIN 16 OF J101. BEFORE S/N 259 ALL OF THESE POINTS AND PIN 16 WERE CONNECTED DIRECTLY TO THE CHASSIS.
- REFERENCE DESIGNATIONS IN USE:
- 8101-105
 - C1-20, 201-207, 309
 - CR1-2, 4-7, 201-214
 - J101-104
 - K201
 - L1
 - M101-102
 - P101
 - Q1-10, 201-205
 - R3-8, 10-26, 201-211, 213-220, 401-405, 407-429
 - S101-105
 - T1-4

FUNCTIONAL SCHEMATIC k

MODEL 540B

TRANSFER STANDARD

MODEL 540B SER. NO. 11 & ON

FLUKE JOHN FLUKE MFG. CO., INC.
P.O. Box 7428 Seattle, Washington 98133

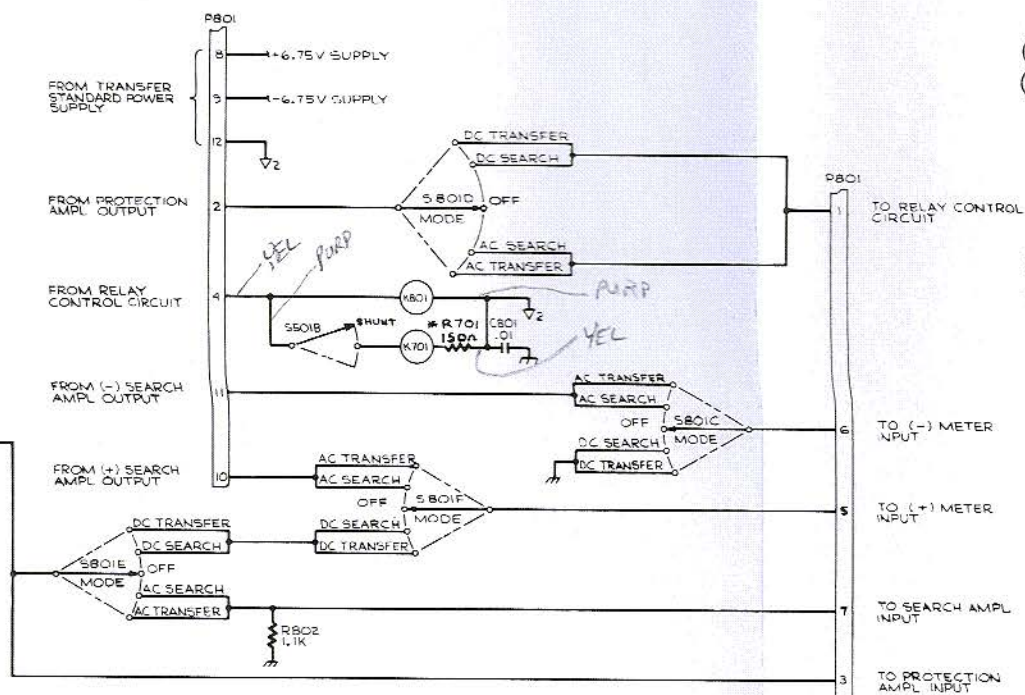

CHANGES:

- ① C608 was added at S/N 476 and on.
- ② For S/N 619 and on:
 C601 was factory selected.
 C602 was 820 pf.
 C603 was 80 to 480 pf variable.
 C606 was 2200 pf.
 C607 was 80 to 480 pf variable.

NOTES:

1. Unless otherwise indicated, resistances are inohms and all capacitances are in micro-farads.
2. ⊗ Indicates Internal Adjustment.
3. * Indicates factory selected part -- Nominal value may be shown.
4. ∇_2 Indicates 13.5V supply common
5. ∇_3 Indicates common ground connection connected to the chassis at the front panel. Before S/N 259 these points were connected directly to the chassis.

REFERENCE DISIGNATIONS:

- C501-520, 601-608, 701, 801
- CR501-506
- DS601
- J801-806
- K701, 801
- P801
- R502-529, 601-602, 701-706, 802
- S501, 801-803
- TC801

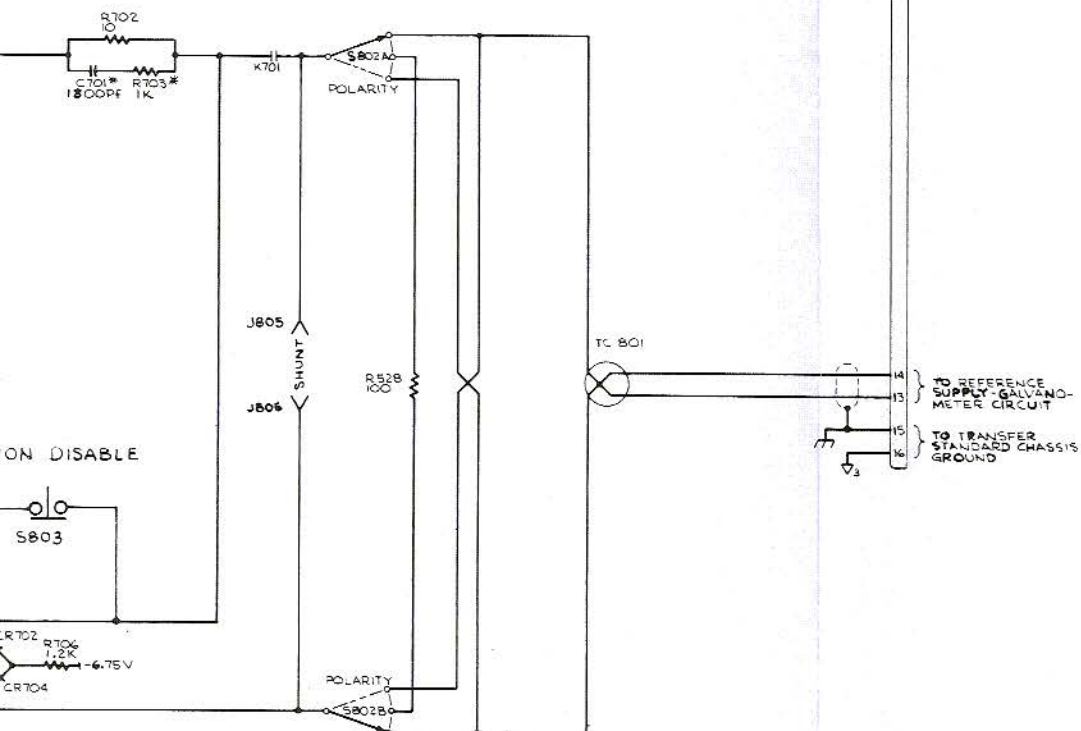

FUNCTIONAL SCHEMATIC	b
MODEL A54-2	
VOLTAGE PLUG-IN UNIT	
MODEL A54-2 SER. NO. 3394 ON	
JOHN FLUKE MFG. CO., INC. <small>P. O. Box 112 Seattle, Washington 98101</small>	

Change/Errata Information

Issue No: 5 8/79

This change/errata contains information necessary to ensure the accuracy of the following manual. Enter the corrections in the manual if either one of the following conditions exist:

1. The instrument's pcb revision letter is equal to or higher than that which is indicated at the beginning of the change.
2. No revision letter is indicated at the beginning of the change/errata.

MANUAL

Title: MODEL 540B THERMAL TRANSFER STANDARD
Print Date: MARCH 1968
Rev and Date:

C/E PAGE EFFECTIVITY

Page No.	Print Date
1	11/77
2	6/79
3	8/79

CHANGE #1 – 3071

On page 5-14, delete the entries for the following items:

Shunt Retaining Screw
Holder
Knob

On page 5-15, delete the following part numbers and corresponding mechanical parts from Figure 5-6:

2405-158949
2102-103283
3153-177485

CHANGE #2 – 8021

On page 5-12, delete the existing entries for diodes CR307 and CR314 and replace each with the following:

Diode, Si; 4805-375907; 07263; FD7222; (CR307) 2, (CR314) REF

CHANGE #3 – 11053

On page 5-10, change the description, Fluke stock no, mfr, and mfr part no for transistors Q7 and Q9

From: type 2N1307, 4805-148643, 01295, 2N1307
To: Si, PNP, 4818-341081; 07263; 2N4121

ERRATA #1

The 540B-110 Rechargeable Battery Pack is described in the manual as an accessory. Change the manual to indicate that the standard 540B now includes the Rechargeable Battery Pack.

ERRATA #2

On page 5-14 and 5-15 change the Fluke stock no and mfr part no for the Range Switch Cover from 3206-178459 to 3155-178467.

ERRATA #3

On page 2-5, paragraph 2-10-g, change the last sentence to read: and the device should be rechecked for heater-to-couple isolation (see Section 4). Defective elements should be replaced.

On page 4-5, paragraph 4-23, change the last sentence to read: to replace the thermocouple. Replacement of the thermocouple should not require recalibration beyond the DC Rerversal and Heater-to-Couple Isolation tests.

ERRATA #4

On page 5-3, change the Fluke stock no and mfr part no for the Magnetic Modulator/Carrier Amplifier Assembly from 1702-165803 to 1702-242495. Also change 840A-401 in the Fluke stock no column to 540B-410.

On page 5-10 correct the Magnetic Modulator/Carrier Amplifier Assembly's mfr part no from 1702-165803 to 1702-242495.

CHANGE #4-11511

On page 5-22, change the stock number, manufacturer, and part number of J1 and item 2 to read as follows:
 J1; 2109-284166; 82389; EAC301
 2; 6005-284174; 89536; 6005-284174.

ERRATA #5

On page 4-2, paragraph 4-7, replace step F with the following:

- F. With a non-metallic screwdriver, adjust the core of L1 (adjustment J) for a maximum deflection to the right on the Galvanometer meter (approximately 3 to 5 minor divisions is typical deflection).

CHANGE #5 - 12031

Rev. -E, Search and Protection Amplifier Assembly

On page 5-12, make the following changes:

FROM: Q305/Tstr, type 2N1304/4805-117127/01295/2N1304/Ref
 TO: Q305/Tstr, type 2N3904/4819-218396/04713/2N3904/1

Rev. -F, Magnetic Modulator/Carrier Amplifier Assembly

On page 5-10, make the following changes:

FROM: Q6, Q8, Q10/Tstr, type 2N1304/4805-117127/01295/2N1304/Ref
 TO: Q6, Q8, Q10/Tstr, type 2N3904/4819-218396/04713/2N3904/Ref

FROM: Q7, Q9/Tstr, Si, PNP/4818-341081/07263/2N4121/2/1
 TO: Q7, Q9/Tstr, Si, PNP/4818-195974/04713/2N3906/2/1

FROM: R27/Res, comp, 18k \pm 10%, $\frac{1}{2}$ W/4705-108183/01121/EB1831/1
 TO: R27/Res, comp, 30k \pm 5%, $\frac{1}{2}$ W/4704-186015/01121/EB3035/1

FROM: R18/Res, met flm, 19.6k \pm 1%, $\frac{1}{2}$ W/4705-159640/75042/Type CEC-TO/1
 TO: R18/Res, met flm, 34k \pm 1%, $\frac{1}{2}$ W/4705-151241/75042/Type CEC-TO/1

On the Functional Schematic (Transfer Standard) make the following changes:

FROM: R27, 18k TO: R27, 30k
 FROM: R18, 19.6k TO: R18, 34k

Rev. -B, Oscillator/Synchronous Demodulator Assembly

On page 5-9, make the following changes:

FROM: Q4, Q5/Tstr, type 2N1304/4805-117127/01295/2N1304/2/2
 TO: Q4, Q5/Tstr, type 2N3904/4819-218396/04713/2N3904/2/2

ERRATA #6

On page 1-1, under ELECTRICAL, add the following information:

Protection Class #1 (Relates solely to insulation or grounding properties further defined in IEC 348.)

ERRATA #7

On page 5-18:

FROM: R522/Res, WW, 10K \pm 1%, 1W/4707-131664/89536/4707-131664/1
TO: R522/Res, WW, 10K \pm 1%, 1W/4707-209072/89536/4707-209072/1

CHANGE #6 - 12677

Rev. -C, Oscillator/Synchronous Demodulator Assembly (840A-402)
Rev. -G, Magnetic Modulator/Carrier Amplifier Assembly (540B-410)

On page 5-10:

FROM: R27/Res, comp, 30K \pm 5%, $\frac{1}{2}$ W/4704-18601/01121/EB3035/1
TO: R27/Res, comp, 18K \pm 5%, $\frac{1}{2}$ W/4704-187898/01121/EB1845/1

On page 5-9:

FROM: R8/Res, comp, 2.2K \pm 10%, $\frac{1}{2}$ W/4704-108605/01121/EB2221/REF
TO: R8/Res, comp, 8.2K \pm 5%, $\frac{1}{2}$ W/4704-147777/01121/EB8225/1

On the Functional Schematic (Transfer Standard):

FROM: R27, 30K TO: R27, 18K
FROM: R8, 2.2K TO: R8, 8.2K